



ACVATIX™

Combi valves PN 16 with VPF43.. flanged connections

Pressure Independent Combi Valves

-
- With integrated pressure differential controller
 - Valve body made of gray cast iron GJL-250
 - DN 50, DN 65 and DN 80
 - Volumetric flow 15 to 43 m³/h nominal, with presetting
 - Equipped with pressure test points P/T
 - Can be equipped with SAX..P.. or SQV..P.. electromotoric actuators

Use

- For use in heating, ventilating and air conditioning systems as a control valve.
- For closed circuits.

Type summary

	Product number	Stock number	DN	H ₁₀₀ [mm]	\dot{V}_{\min} [m ³ /h]	\dot{V}_{100} [m ³ /h]	Δp_{\min} [kPa]
Standard flow rate	VPF43.50F16	S55266-V100	50	20	2.3	15	35
	VPF43.65F24	S55266-V102	65		4.4	25	
	VPF43.80F35	S55266-V104	80		5.3	34	
High flow rate	VPF43.50F25	S55266-V101	50	20	4.3	25	70
	VPF43.65F35	S55266-V103	65		6	35	
	VPF43.80F45	S55266-V105	80		7	43	

DN = nominal size

H₁₀₀ = nominal stroke

\dot{V}_{100} = volumetric flow through fully open valve (H₁₀₀)

\dot{V}_{\min} = smallest presettable volumetric flow through fully open valve (H₁₀₀)

Δp_{\min} = minimum differential pressure required across the valve's control path, so that the difference pressure regulator works reliably

Ordering

Example:

Product number	Stock number	Designation
VPF43.65F24	S55266-V102	Combi valve PN 16 with flanged connections

Delivery

Combi valves, actuators and accessories are packed and supplied separately. The valves are supplied without counter-flanges and without flange gaskets.

Revision numbers

See page 10

Equipment combinations

Valves				Actuators			
				SAX..P.. ¹⁾		SQV..P..	
		DN	H ₁₀₀ [mm]	Δp _{max} [kPa]	Δp _s [kPa]	Δp _{max} [kPa]	Δp _s [kPa]
Standard flow rate	VPF43.50F16	50	20	600	600	600	600
	VPF43.65F24	65		600	600	600	600
	VPF43.80F35	80		600	600	600	600
High flow rate	VPF43.50F25	50	20	600	600	600	600
	VPF43.65F35	65		600	600	600	600
	VPF43.80F45	80		600	600	600	600

H₁₀₀ = nominal stroke

Δp_{max} = maximum permissible differential pressure across the valve's control path, valid for the entire actuating range of the motorized valve

Δp_s = maximum permissible differential pressure at which the motorized Combi valve will close securely against the pressure (close off pressure)

¹⁾ Media temperature limit 100°C

Actuator overview

Type	Stock no.	Stroke	Pos. force	Operating voltage	Positioning signal	Spring return time	Spring return direction	Positioning time	LED	Manual adjuster	Extra functions
SAX31P03 Y	S55150-A118-A998	20 mm	500 N	AC 230 V	3-position	-	-	30 s	-	Push and fix	¹⁾
SAX61P03 Y	S55150-A114-A998			AC/DC 24 V	DC 0...10 V DC 4...20 mA 0...1000 Ω				✓		^{2), 3)}
SAX81P03 Y	S55150-A116-A998			3-position	-				-		30 s
SQV91P30	S55150-A130	20 mm	1100 N	AC/DC 24 V	3-position	30 s	Pull to open or push to close ⁵⁾	< 120 s ⁵⁾	✓	Turn and fix	^{1), 6)}
SQV91P40	S55150-A131	40 mm		AC 230 V ⁴⁾	DC 0...10 V DC 4...20 mA						

¹⁾ Optional accessories: Auxiliary switch, potentiometer

²⁾ Position feedback, forced control, change of flow characteristic

³⁾ Optional accessories: Auxiliary switch, sequence control, acting direction

⁴⁾ Voltage adapter required, order separately

⁵⁾ Selectable

⁶⁾ Position feedback

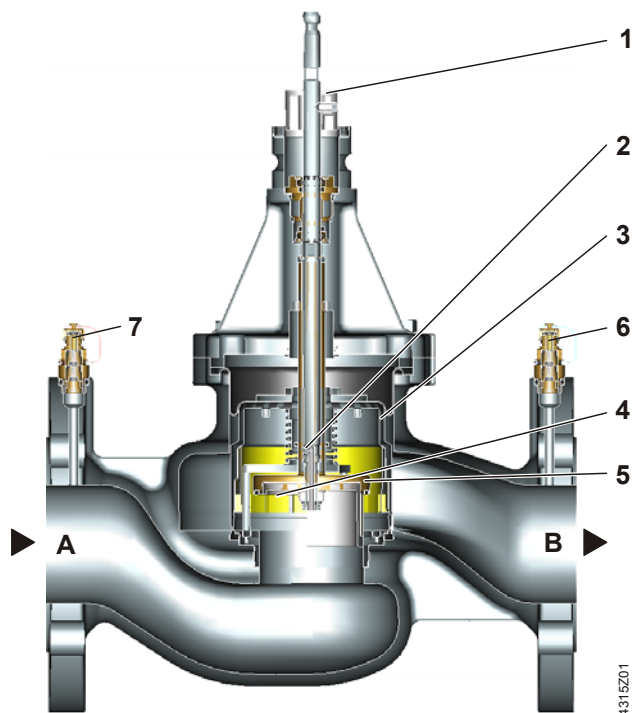

1 Ring with dial for presetting

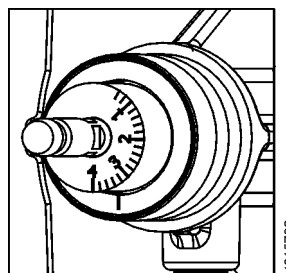

2 Aperture for the differential pressure controller is linked with outlet port B

3 Differential pressure controller

4 Plug with variable presetting opening

5 Control valve

6 Pressure test point (P/T) at outlet port B, blue ribbon, P-

7 Pressure test point (P/T) at inlet port A, red ribbon, P+

A Inlet port A

B Outlet port B

Functional principle

The Combi valves VPF43.. combine three functions:

- a control valve (5) for controlling the volumetric flow,
- an adjusting mechanism (1, 4) with a dial for a presettable maximum volumetric flow,
- a differential pressure controller (3) for balancing pressure fluctuations in the hydraulic system respectively across the control valve.

The mechanical series-connected differential pressure controller keeps the differential pressure ($p_1 - p_2$) constant across the control valve and thus the set volumetric flow too. The desired maximum volumetric flow can be preset with the adjusting mechanism. The controller (not shown) and the actuator regulate the volumetric flow and consequently the desired temperature in buildings, rooms or zones.

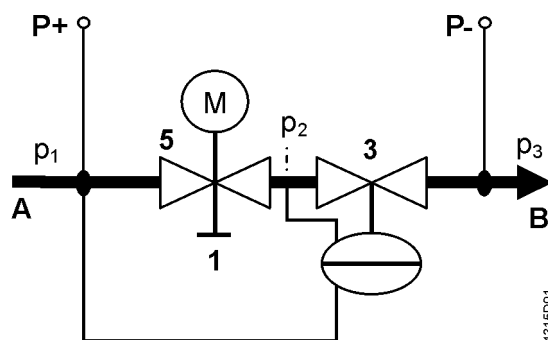

A Inlet medium (inlet port A)

B Outlet medium (outlet port B)

1 Ring with dial for presetting

3 Differential pressure controller

5 Control valve with mounted actuator

- P- = P/T port, pressure test point with blue ribbon (6)
- P+ = P/T port, pressure test point with red ribbon (7)
- p_1 = pressure at inlet port A of Combi valve
- p_2 = pressure at outlet port of control valve (5)
- p_3 = pressure at outlet port B of Combi valve

Medium flow The medium entering the Combi valve (inlet port A) first passes through the control valve (5) with a linear characteristic and a stroke of 20 mm (DN 50...80) respectively 40 mm (DN 100...150). The actuator (not shown here) opens and accurately positions the control valve. Then, the medium flows through the variable presetting opening (4) which is connected to the ring with dial (1) for presetting the desired maximum volumetric flow. Before leaving the Combi valve (outlet port B), the medium passes through a built-in mechanical differential pressure controller (3). This differential pressure controller is the heart of the Combi valve and ensures that the selected volumetric flow is maintained across the whole working range and independent of the inlet pressure p_1 .

Pressure test points The Combi valve VPF43.. is equipped with two pressure test points (P+, P-) for measuring and monitoring the differential pressure across the valve during commissioning. For that purpose, the electronic manometer ALE10 can be used.

Manual control Manual control is only possible with mounted actuator.







Advantages

The advantages of Combi valves are that:

- once the flow limiter is set to design flow, the hydraulic circuit self balances, even when changes to the system are made, such as additions.
- for any heat demand the Combi valve with mounted actuator can be set to the desired volumetric flow and will be relatively constant regardless of pressure fluctuations in the system.

Constant flow regardless of pressure changes in the system reduces hydraulic interdependence and leads to a more stable control.

Accessories

Product no.	Stock no.		Beschreibung
ALE10	ALE10		Electronic manometer excluding measuring lines and measuring tips. Measuring range 700 kPa, max. 1000 kPa. For measuring the differential pressure between P+ and P- of the Combi valves (refer to diagram under "Functional principle" on page 4). Functions of the manometer: <ul style="list-style-type: none"> • Start/stop • Automatic zero position • Backlit display • Display: Out → outside the measuring range • Holding function
ALE11	ALE11		Measuring lines and straight measuring tips for use with Siemens Combi valves. Equipped with G 1/8" connection with 2 x 40 mm needles.
ALP46	S55264-V115		Blanking plugs for P/T ports Connection to valve body: G 1/4" to ISO 228, inclusive O-ring
ALP47	S55264-V116		Drain ball valve inclusive O-ring Port: External threads G 1/2" to ISO 228 Connection to valve body: G 1/4" to ISO 228, inclusive O-ring
ALP48	S55264-V117		Combined P/T port and drain ball valve with red ribbon Port: External threads G 1/8" to ISO 228 Connection to valve body: G 1/4" to ISO 228, inclusive O-ring
ALP49	S55264-V118		Long P/T ports (set of 2 pieces) Set contains 1 piece each with a red and blue ribbon. Port: External threads G 1/8" to ISO 228 Connection to valve body: G 1/4" to ISO 228, inclusive O-ring

Engineering example

Basis of design

1. Determine heat demand Q [kW]
2. Determine temperature spread ΔT [K]
3. Calculate volumetric flow

$$\dot{V} = \frac{Q[\text{kW}] \cdot 1000}{1.163 \cdot \Delta T[\text{K}]} \left[\frac{\text{l}}{\text{h}} \right]$$
4. Select suitable Combi valve VPF43..
5. Determine dial setting using volumetric flow/dial presetting tables, see below.

Example

1. Heat demand $Q = 150 \text{ kW}$
2. Temperature spread $\Delta T = 6 \text{ K}$
3. Volumetric flow

$$\dot{V} = \frac{150 \text{ kW} \cdot 1000}{1.163 \cdot 6 \text{ K}} = 21654 \text{ l/h} = 21.6 \text{ m}^3/\text{h}$$

Hint: You can also determine the volumetric flow using the valve slide rule.

4. Select Combi valve VPF43..
Ideally, Combi valves should be selected such that they operate at about 80% of their maximum flow, enabling them to deliver spare capacity, if required.

Selection: VPF43.65F24 $\Delta p_{\min} = 35 \text{ kPa}$
VPF43.65F35 $\Delta p_{\min} = 70 \text{ kPa}$

5. Determine dial setting using volumetric flow/dial presetting tables:

VPF43.65F24	Volumetric flow	21.6 m ³ /h
	Dial setting	3.6
VPF43.65F35	Volumetric flow	21.6 m ³ /h
	Dial setting	2.7

Volumetric flow/dial presetting

Tables to determine the dial setting for a desired volumetric flow.

Nominal flow

Standard flow rate

VPF43.50F16

16 m³/h nominal

[m ³ /h]				2.3	3	3.8	4.5	5.3	6	6.8	7.5	8.3	9	9.8	10.5	11.3	12	12.8	13.5	14.3	15
Dial	Min.	0.2	0.4	0.6	0.8	1	1.2	1.4	1.6	1.8	2	2.2	2.4	2.6	2.8	3	3.2	3.4	3.6	3.8	4

VPF43.65F24

24 m³/h nominal

[m ³ /h]				4.4	5.6	6.6	7.7	8.6	9.6	10.5	11.5	12.5	13.5	14.7	15.8	17.1	18.5	19.9	21.5	23.2	25
Dial	Min.	0.2	0.4	0.6	0.8	1	1.2	1.4	1.6	1.8	2	2.2	2.4	2.6	2.8	3	3.2	3.4	3.6	3.8	4

VPF43.80F35

35 m³/h nominal

[m ³ /h]				5.3	6.9	8.3	9.6	10.9	12.2	13.5	14.8	16.2	17.6	19.1	20.7	22.4	24.3	26.4	28.7	31.2	34
Dial	Min.	0.2	0.4	0.6	0.8	1	1.2	1.4	1.6	1.8	2	2.2	2.4	2.6	2.8	3	3.2	3.4	3.6	3.8	4

High flow rate

VPF43.50F25

25 m³/h nominal

[m ³ /h]				4.3	5.2	6.2	7.2	8.1	9	10	11	12.1	13.2	14.3	15.4	16.5	18.2	19.9	21.6	23.3	25
Dial	Min.	0.2	0.4	0.6	0.8	1	1.2	1.4	1.6	1.8	2	2.2	2.4	2.6	2.8	3	3.2	3.4	3.6	3.8	4

VPF43.65F35

35 m³/h nominal

[m ³ /h]				6.0	7.6	9.1	10.5	11.9	13.3	14.7	16.0	17.5	19.0	20.6	22.3	24.1	26.0	28.0	30.2	32.5	35
Dial	Min.	0.2	0.4	0.6	0.8	1	1.2	1.4	1.6	1.8	2	2.2	2.4	2.6	2.8	3	3.2	3.4	3.6	3.8	4

VPF43.80F45

45 m³/h nominal

[m ³ /h]				7	9	11	12.8	14.5	16.2	18	19.6	21.4	23.2	25.1	27.1	29.3	31.6	34.1	36.8	39.8	43
Dial	Min.	0.2	0.4	0.6	0.8	1	1.2	1.4	1.6	1.8	2	2.2	2.4	2.6	2.8	3	3.2	3.4	3.6	3.8	4

Engineering notes

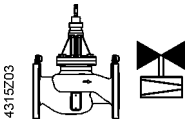
Valve	Symbols / Direction of flow VPF43..	Flow in control mode		Valve stem	
		Inlet	Outlet	retracts	extends
Combi valve		variable	variable	closes	opens



The direction of flow indicated (arrow on the valve body) is mandatory!

The valves should preferably be mounted in the return pipe where temperatures are lower and where the sealing gland is less affected by strain.

Symbol

Symbol used in catalogs and application descriptions	Symbol used in diagrams
	There are no standard symbols for Combi valves in diagrams.

Recommendation

A strainer or dirt trap should be fitted upstream of the valve to enhance reliability and service life.

Remove dirt, welding beads etc. from valves and pipes.

Do not insulate the actuator bracket, as air circulation must be ensured!

Mounting notes

Combi valve and actuator can be easily assembled on site. Neither special tools nor adjustments, besides the presetting, are required. Prior to mounting the actuator, the required volumetric flow must be set. The valve is supplied with Mounting Instructions (74 319 0711 0).

Mounting positions

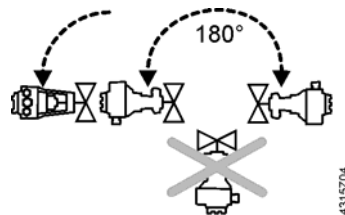

Installation notes

Presetting

It is recommended to mount the actuator before the presetting is made.

1. Mount actuator and fix valve neck coupling
2. Mount valve stem coupling and tighten slightly
3. Make presetting according to table under "Volumetric flow/dial presetting" on page 6. Do NOT adjust presetting to a dial reading lower than "0.6".
4. Tighten stem coupling

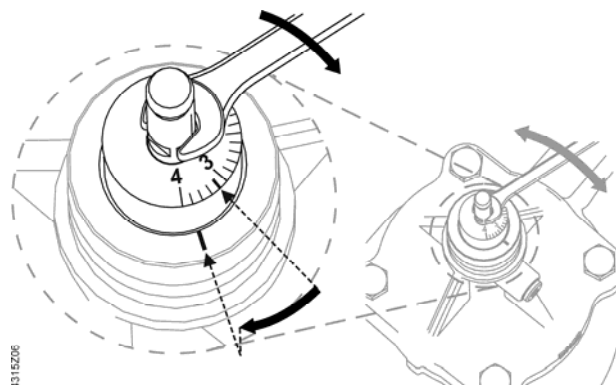

8 mm

Using an open-end wrench and turn the stem with dial to the desired presetting position.

Valve characteristic

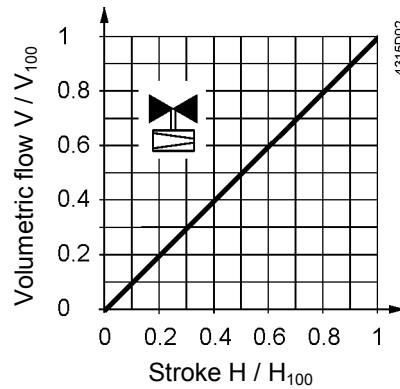

Working pressure and medium temperature

Fluids

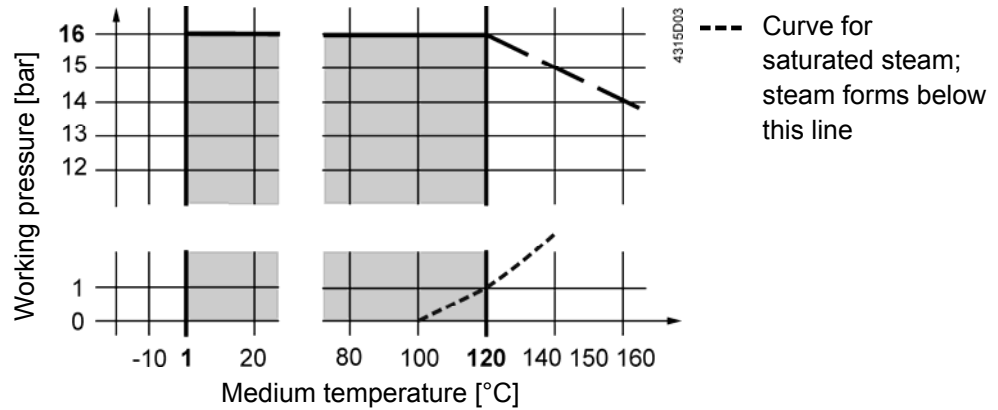

Working pressure and medium temperature staged as per ISO 7005



Current local legislation must be observed.

Commissioning notes



The valves must be commissioned with the actuator correctly fitted. Strong pressure impacts can damage closed Combi valves.



The Combi valves have to be open when flushing or pressure testing the system. Strong pressure impacts can damage closed Combi valves.



Differential pressure Δp_{max} across the valve's control path is not allowed to exceed 600 kPa.

Manual control

Only possible with mounted actuator.

Maintenance notes

The VPF43.. Combi valves are maintenance-free.



When performing service work on the valve or actuator:

- Switch off the pump and disconnect power supply.
- Close the shut-off valves in the piping network.
- Fully reduce pressure in the piping network and allow the pipes to cool down completely.

Remove the electrical connections only if necessary.

Sealing gland

The stem sealing gland cannot be exchanged. In case of leakage the whole valve must be replaced.



Due to the different types of material used, the valve must be disassembled prior to disposal. Special handling of certain valve components may be required by law or may be sensible from an ecological point of view.

Local and currently valid legislation must be observed.

Warranty

Application-related technical data are guaranteed only when the valves are used in connection with the Siemens actuators listed under "Equipment combinations" on page 3.

Siemens warranty is void, if used with non-Siemens actuators.

Technical data

Functional data	PN class	PN 16 as per EN 1333		
	Permissible operating pressure	1600 kPa (16 bar) as per ISO 7628 / EN 1333		
	Volumetric flow deviation	< ±10% within differential pressure range		
	Valve characteristic	Linear as per VDI/VDE 2173		
	Leakage rate	Class IV (0...0.01% of volumetric flow \dot{V}_{100}) to EN 1439		
	Operating direction	Normally open (push to close)		
	Permissible media	Low temperature hot water, medium temperature hot water, chilled water, water with antifreeze Recommendation: Water treatment to VDI 2035		
	Medium temperature	1...120 °C		
	Rangeability	1:100		
	Nominal stroke	DN 50...DN 80	20 mm	
	Standards	Pressure Equipment Directive	PED 97/23/EC	
Pressure Accessories		As per article 1, section 2.1.4		
Fluid group 2		DN 50	Without CE-marking as per article 3, section 3 (sound engineering practice)	
		DN 65, DN 80	Category I, with CE-marking	
Environmental compatibility		ISO 14001	(Environment)	
	ISO 9001	(Quality)		
	SN 36350	(Environmentally compatible products)		
	RL 2002/95/EG	(RoHS)		
Materials	Valve body	Gray cast iron GJL-250		
	Stem, spring	Stainless steel		
	Trim	Brass (DZR)		
	Regulator	Stainless steel		
	Seals	EPDM		

Dimensions / weight	Dimensions	Refer to "Dimensions" on page 10		
	Flange connections	To ISO 7005-2		
	Pressure test points (P/T-ports)	G ¼ inch (connection) 2 mm x 40 mm (measuring tips)		
	Weight	Refer to "Dimensions" on page 10		
General ambient conditions		Operation	Transport	Storage
		EN 60721-3-3	EN 60721-3-2	EN 60721-3-1
	Environmental conditions	Class 3K5	Class 2K3	Class 1K3
	Temperature	-15...+55 °C	-30...+65 °C	-15...+50 °C
	Humidity	5...95 % r.h.	< 95 % r.h.	5...95 % r.h.

Application examples

It is recommended to use Combi valves in plants with variable speed pumps. When sizing the pump, it must be made certain that the most critical branch or consumer in the system – usually the remotest from the pump – gets enough pressure (pump head).

Dimensions

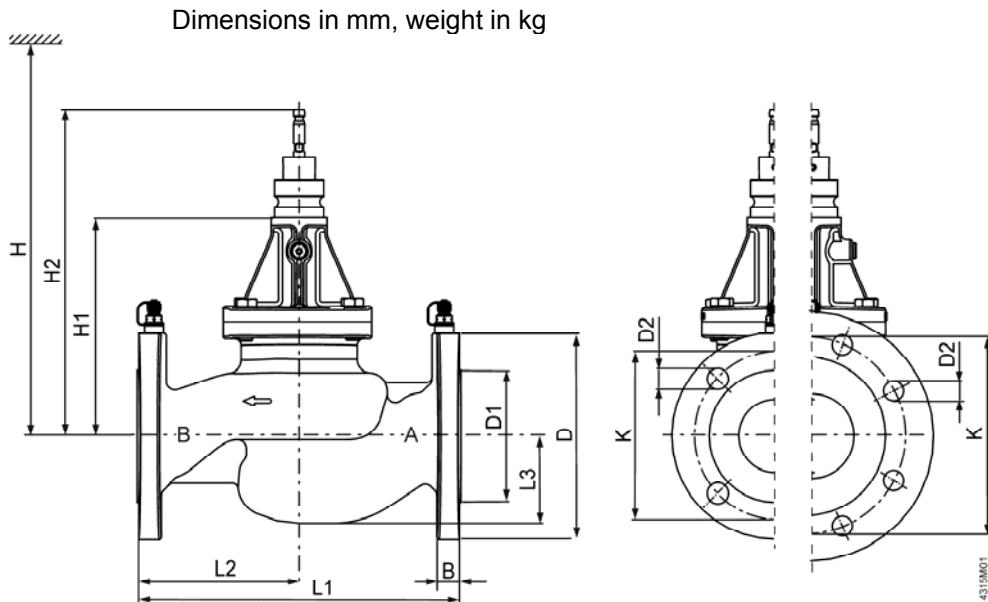

DN 50 / DN 65 DN 80

Product number	DN	B	Ø D	Ø D1	Ø D2	L1	L2	L3	Ø K	H1	H2	H		kg
												SAX..P	SQV..P	
VPF43..	50	16	165	99	19 (4x)	230	115	65	125	187.5	284	630	577	14
	65	17	185	118	19 (4x)	290	145	84	145	195	291,5	637	584	19.5
	80	17	200	132	19 (8x)	310	155	90,5	160	216.5	313	659	606	25

DN = Nominal size

H = Total actuator height plus minimum distance to the wall or the ceiling for mounting, connection, operation, maintenance etc.

H1 = Dimension from the pipe center to install the actuator (upper edge)

H2 = Valve in the «CLOSED» position means that the valve stem is fully retracted.

Revision Numbers

Product number	Valid from rev. no.	Product number	Valid from rev. no.
VPF43.50F16	..A	VPF43.50F25	..A
VPF43.65F24	..A	VPF43.65F35	..A
VPF43.80F35	..A	VPF43.80F45	..A