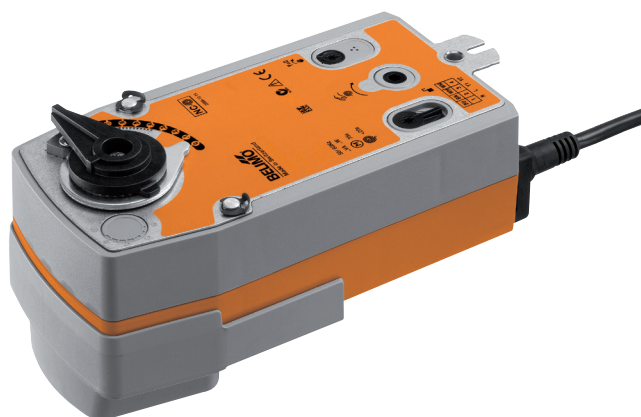

Rotary actuator with emergency control function for ball valves

- Nominal torque 20 Nm
- Nominal voltage AC/DC 24 V
- Control Open-close
- Deenergised open (NO)

**Technical data**

<b>Electrical data</b>	Nominal voltage	AC/DC 24 V
	Nominal voltage frequency	50/60 Hz
	Nominal voltage range	AC 19.2...28.8 V / DC 21.6...28.8 V
	Power consumption in operation	4.5 W
	Power consumption in rest position	2.5 W
	Power consumption for wire sizing	6.5 VA
	Connection supply / control	Cable 1 m, 2 x 0.75 mm <sup>2</sup>
	Parallel operation	Yes (note the performance data)
<b>Functional data</b>	Torque motor	Min. 20 Nm
	Torque spring return	Min. 20 Nm
	Direction of rotation spring-return	Deenergised NO, valve open (A - AB = 100%)
	Manual override	By means of hand crank and locking switch
	Angle of rotation	90°
	Running time motor	75 s / 90°
	Running time emergency setting position	<20 s / 90°
	Sound power level motor max.	45 dB(A)
	Position indication	Mechanical
	Service life	Min. 60,000 emergency positions
	<b>Safety</b>	Protection class IEC/EN
Protection class UL		UL Class 2 Supply
Degree of protection IEC/EN		IP54
Degree of protection NEMA/UL		NEMA 2, UL Enclosure Type 2
EMC		CE according to 2004/108/EC
Certification IEC/EN		IEC/EN 60730-1 and IEC/EN 60730-2-14
Certification UL		cULus according to UL 60730-1A, UL 60730-2-14 and CAN/CSA E60730-1:02
Mode of operation		Type 1.AA
Rated impulse voltage supply / control		0.8 kV
Control pollution degree		3
Ambient temperature		-30...50°C
Non-operating temperature	-40...80°C	
Ambient humidity	95% r.h., non-condensing	
Maintenance	Maintenance-free	
<b>Weight</b>	Weight approx.	2.3 kg

**Safety notes**

- This device has been designed for use in stationary heating, ventilation and air conditioning systems and is not allowed to be used outside the specified field of application, especially in aircraft or in any other airborne means of transport.
- Only authorised specialists may carry out installation. All applicable legal or institutional installation regulations must be complied during installation.
- The device may only be opened at the manufacturer's site. It does not contain any parts that can be replaced or repaired by the user.
- The cables must not be removed from the device.

### Safety notes

- The device contains electrical and electronic components and is not allowed to be disposed of as household refuse. All locally valid regulations and requirements must be observed.

### Product features

<b>Mode of operation</b>	The actuator moves the valve to the operating position at the same time as tensioning the return spring. The valve is turned back to the emergency position by spring force when the supply voltage is interrupted.
<b>Direct mounting</b>	Simple direct mounting on the ball valve with only one screw. The mounting orientation in relation to the ball valve can be selected in 90° steps.
<b>Manual override</b>	Manual actuation of the valve with manual elevator crank, engagement with the locking switch at any position. Unlocking is manual or automatic by applying the operating voltage.
<b>High functional reliability</b>	The actuator is overload protected, requires no limit switches and automatically stops when the end stop is reached.
<b>Adjustable angle of rotation</b>	Adjustable angle of rotation with mechanical end stop.

### Electrical installation



#### Notes

- Connection via safety isolating transformer.
- Parallel connection of other actuators possible. Observe the performance data.

### Wiring diagrams

AC/DC 24 V, open-close

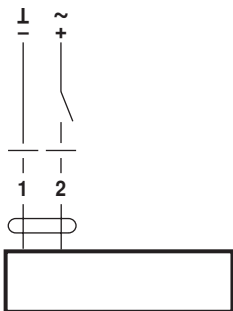

#### Cable colours:

- 1 = black  
2 = red

## Dimensions [mm]

## Dimensional drawings

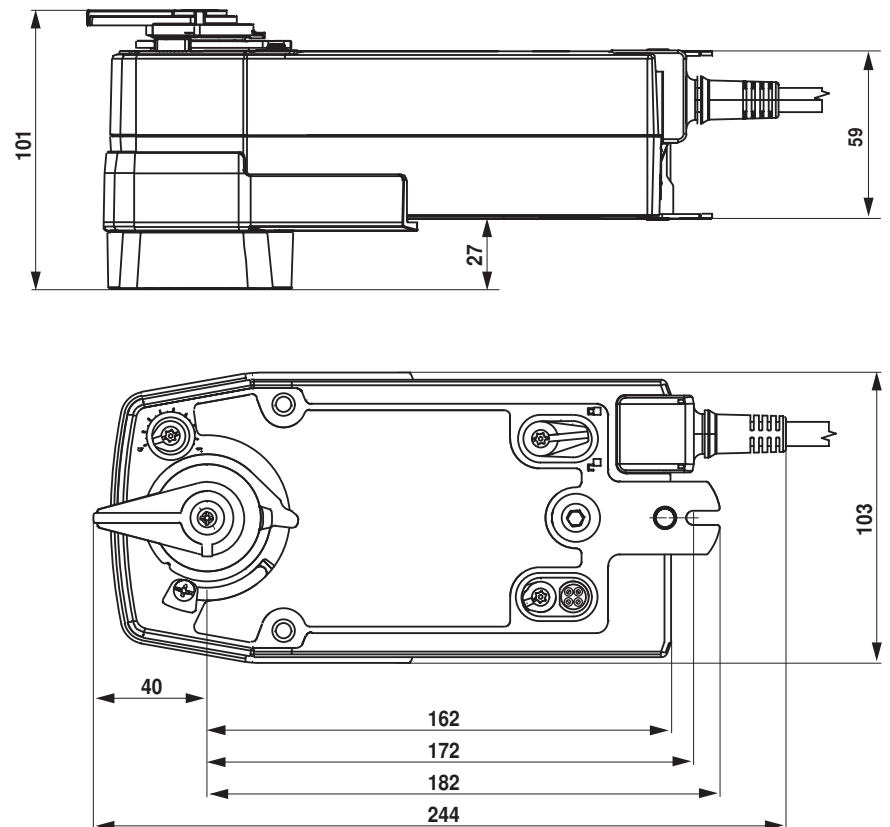

## Further documentation

- Overview Valve-actuator combinations
- Data sheets for ball valves
- Installation instructions for actuators and/or ball valves
- General notes for project planning