



Actuator SQM40.../SQM41...

## Actuators for air and gas dampers

**SQM40...  
SQM41...**

- Electromotoric actuator up to 10 Nm
- Clockwise and counterclockwise variants
- Running times from 15 and 30 seconds
- Various shaft ends available
- Electronic version with analog control input
- Internal position indication
- Drive shaft can be disengaged
- UL approval

The SQM40.../SQM41... and this Data Sheet are intended for use by OEMs which integrate the actuators in their products!

### Use

The SQM40.../SQM41... actuators are suited for driving flow control valves, butterfly valves, dampers or for use on other applications that require rotary motion. Areas of application are oil and gas burners of medium to higher capacity as well as thermal process plants.

The actuators are used primarily for load-dependent control of the flow of gas, oil and combustion air:

- In connection with 3-position or modulating controllers (e.g. 4...20 mA), or
- Directly by burner controls

## Warning notes

---



**To avoid injury to persons, damage to property or the environment, the following warning notes must be observed!**

**Only qualified personnel may open, interfere with or modify the actuators!**

- Read the documentation on the actuators carefully and fully. If not observed, dangerous situations might occur
- All product-related activities (mounting, settings and maintenance) must be performed by qualified and authorized personnel



### **Caution!**

- Risk of electric shock hazard – to disconnect the actuator from power, it may be necessary to open more than one switch. Before performing maintenance work, the actuator must be disconnected from power
- The electrical connection between the conduit fittings is not made automatically. It must be established on installation site
- The connecting plate is made of plastic and does not provide earthing of the conduit fittings. Earthing must be ensured by adequate washers and wire links
- To provide protection against electric shock hazard, the connecting terminals must have adequate touch protection. Make certain that non-insulated connections or wires cannot be touched
- Each time work has been carried out (mounting, installation, service work, etc.), check to ensure that wiring is in an orderly state
- Fall or shock can adversely affect the safety functions. Such actuators must not be put into operation even if they do not exhibit any damage
- Static charges must be avoided since they can damage the actuator's electronic components when touched.

**Recommendation:** Use ESD equipment

### **Notes on use in North America**

- Use of flexible conduit including adequate accessories is mandatory
- Use of copper wiring is mandatory
- All circuits of class 2 must use cables type CL3, CL3R, CL3P or comparable types,  
OR  
All circuits are wired according to class 1 (electrical light or power circuits)

## Mounting notes

- Ensure that the relevant national safety regulations and notes on standards are complied with
- In geographical areas where DIN regulations apply, the mounting and installation requirements of VDE must be satisfied, especially DIN/VDE 0100, 0550 and DIN/VDE 0722
- Make certain that the actuator is not exposed to direct solar radiation
- Required tightening torques:
  - Cover screws: 3.5 Nm
  - Connecting cover: 2 Nm

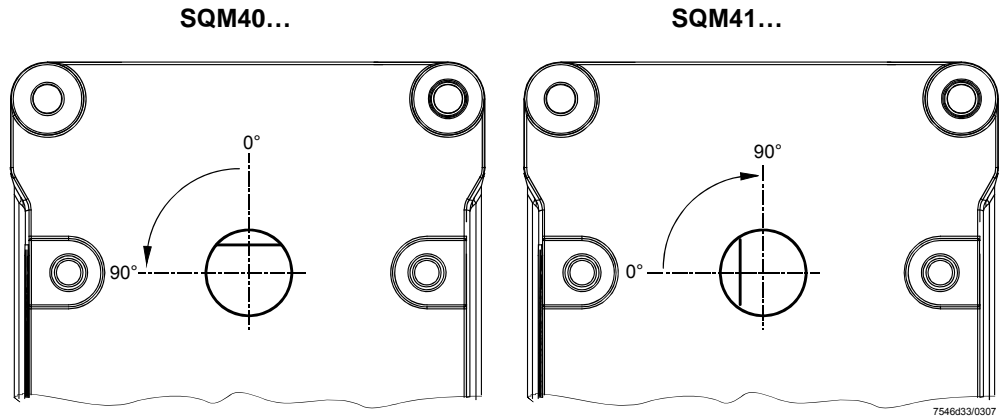

Figure: Note for direction of rotation

## Installation notes

- Ensure that the electrical wiring is in compliance with national and local safety regulation
- Make certain that strain relief of the connected cables conforms to the relevant standards (e.g. as per DIN EN 60730 and DIN EN 60335)
- Ensure that spliced wires cannot get into contact with neighboring terminals. Use adequate ferrules
- Unused terminals of the SQM40.../SQM41... must be covered by dummy plugs
- When making the wiring, the AC 120 V or AC 230 V section must be strictly separated from other voltage sections, thus ensuring protection against electric shock hazard
- The mechanical coupling between actuators and controlling elements must be form-fitted

## Electrical connection of the SQM40.../SQM41...

- The actuators must always be powered via a prefuse of max. 6,3 AT (as per DIN EN 60127 2/5)
- For the protective earth connection, the housing of all models has a marked earth terminal

### Marking of the voltage ranges SQM40.../SQM41...:

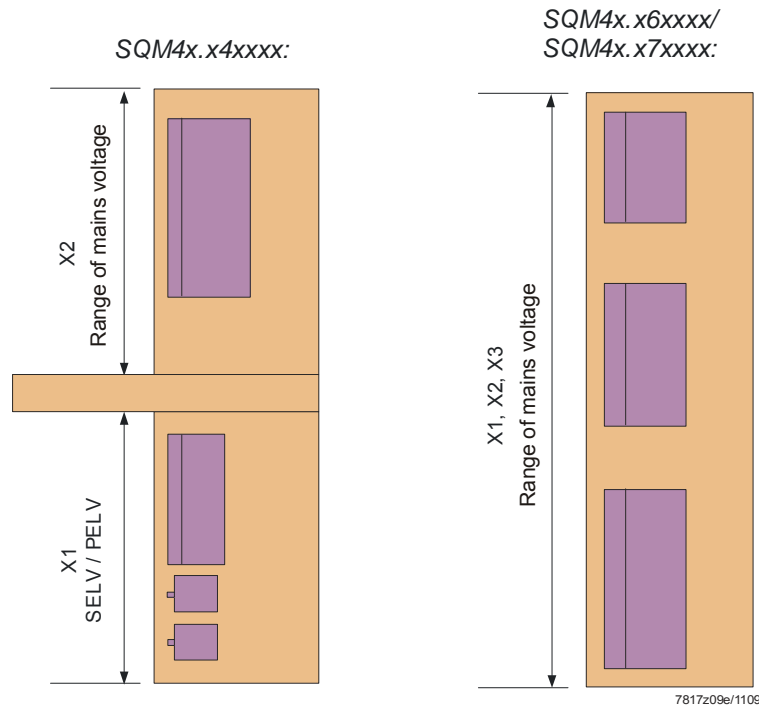

Figure: Electrical connection of the SQM40.../SQM41...



#### Note

SELV or PELV depends on the safety class of the connected components. In the case of PELV, the relevant component is connected to protective earth.

## Settings of the SQM40.../SQM41...

The mechanical setting facility for the cam switches is physically separated from the connection terminals. When the actuator is disconnected from power, the switches can be adjusted via a scale. The switching points can be changed via adjusting screws. The scale indicates the angles of the switching points.



### Note

Potentiometers for adjustment of the modulation limits:

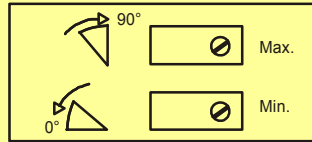

7817z10/1009



### Note

Usable range for the potentiometers:

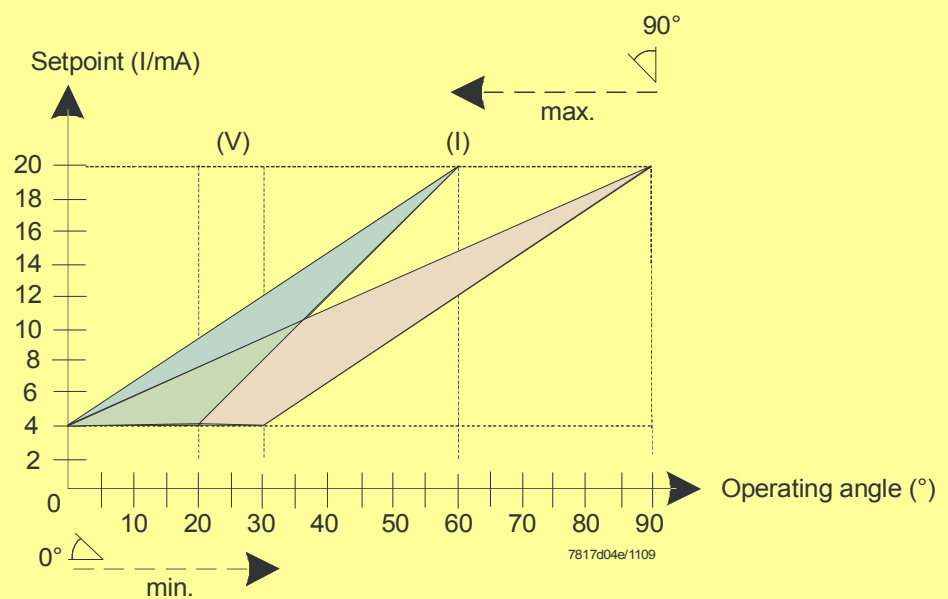

## Standards and certificates



Conformity to EEC directives  
 - Electromagnetic compatibility EMC (immunity)  
 - Low-voltage directive

2004/108/EC  
 2006/95/EC



ISO 9001: 2008  
 Cert. 00739



ISO 14001: 2004  
 Cert. 38233



For use in US/Canada where the power supply lines require a connection facility for flexible conduit, the actuator's product no. includes type suffix «R» (see following example). These products are **UL**-listed.

Example: SQM40.264**R**10

## Disposal notes



The unit contains electrical and electronic components and must not be disposed of together with domestic waste.  
 Local and currently valid legislation must be observed.

## Mechanical design

---

- |             |  |
|-------------|--|
| Housing     | <ul style="list-style-type: none"><li>• Housing parts made of die-cast aluminium</li><li>• Covers made of impact-proof and heat-resistant plastic</li></ul>  |
| Drive motor | <ul style="list-style-type: none"><li>• Stall-proof synchronous motor</li></ul>  |
| Couplings   | <ul style="list-style-type: none"><li>• Shaft can be disengaged from motor by coupling (pressing coupling pin «K1»)</li><li>• Automatic reengagement</li></ul> <p>- Disengagement of drive shaft / motor<br/>by pressing coupling pin «K1»</p> |

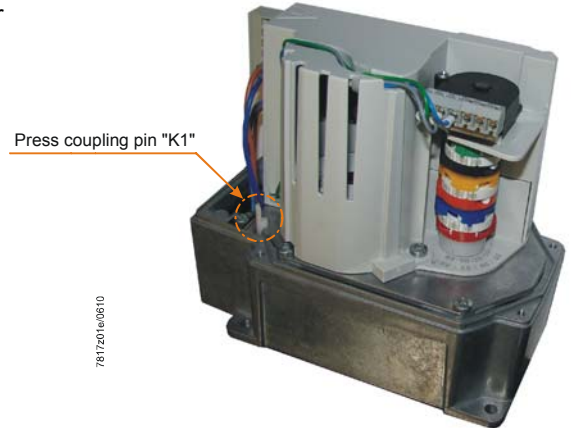

- |                                |   |
|--------------------------------|---|
| Cam shaft drive                | <ul style="list-style-type: none"><li>• Non-reactive gear</li></ul>   |
| Adjustment of switching points | <ul style="list-style-type: none"><li>• With adjustable cams</li><li>• Scales beside the cams indicate the angle of the switching point</li></ul>   |
| Position indicator             | <ul style="list-style-type: none"><li>• Internally<ul style="list-style-type: none"><li>– Scale 0...90° at the base of the cam assembly</li><li>– Scale range to direction of rotation with arrow and «R» or «L» marked</li></ul></li></ul>   |
| Electrical connections         | <ul style="list-style-type: none"><li>• RAST3.5 screw terminals are enclosed, depending on the PCB variant</li><li>• RAST5 screw terminals are enclosed, depending on the PCB variant</li><li>• Optional: Insulation displacement connectors</li><li>• Wiring through connecting cover</li><li>• Easy insertion of cables through large openings in the housing</li></ul> |
| Gear train                     | <ul style="list-style-type: none"><li>• Maintenance-free gearwheels and bearings</li></ul>  |
| Drive shaft                    | <ul style="list-style-type: none"><li>• Different shaft versions available</li></ul>  |
| Actuator fixing                | <ul style="list-style-type: none"><li>• Fixing holes at housing bottom (drive shaft side), like SQM45.../SQM48... with screws M5 or, alternatively, SQM10.../SQM20... front mounting with self-tapping screws M5</li></ul>  |

Type summary (other types on request)

Product no.	Direction of rotation		Torque	PCB						Shaft no.	Regional version		Operating voltage		Potentiometer	
	Counterclockwise	Clockwise		Electronic	Basic	3-position	2-position	Switches	Relay		EU	US	AC120V	AC230V	Single	Double
SQM40.141A21	●		5Nm/15s	●				3		1	●			●	●	
SQM40.144R11	●		5Nm/15s	●				3		4		●	●		●	
SQM40.145A21	●		5Nm/15s	●				3		5	●			●	●	
SQM40.145R11	●		5Nm/15s	●				3		5		●	●		●	
SQM40.161A20	●		5Nm/15s		●	●		6		1	●			●		
SQM40.164R11	●		5Nm/15s		●	●		6		4		●	●		●	
SQM40.165A20	●		5Nm/15s		●	●		6		5	●			●		
SQM40.165A21	●		5Nm/15s		●	●		6		5	●			●	●	
SQM40.165R11	●		5Nm/15s		●	●		6		5		●	●		●	
SQM40.171A20	●		5Nm/15s		●		●	5	1	1	●			●		
SQM40.174R10	●		5Nm/15s		●		●	5	1	4		●	●			
SQM40.175A21	●		5Nm/15s		●		●	5	1	5	●			●	●	
SQM40.241A11	●		10Nm/30s	●				3		1	●		●		●	
SQM40.241R11	●		10Nm/30s	●				3		1		●	●		●	
SQM40.241A21	●		10Nm/30s	●				3		1	●			●	●	
SQM40.244A21	●		10Nm/30s	●				3		4	●			●	●	
SQM40.244R11	●		10Nm/30s	●				3		4		●	●		●	
SQM40.245A11	●		10Nm/30s	●				3		5	●		●		●	
SQM40.245A21	●		10Nm/30s	●				3		5	●			●	●	
SQM40.245R11	●		10Nm/30s	●				3		5		●	●		●	
SQM40.247A21	●		10Nm/30s	●				3		7	●			●	●	
SQM40.261A11	●		10Nm/30s		●	●		6		1	●		●		●	
SQM40.261R11	●		10Nm/30s		●	●		6		1		●	●		●	
SQM40.261A20	●		10Nm/30s		●	●		6		1	●			●		
SQM40.261A21	●		10Nm/30s		●	●		6		1	●			●	●	
SQM40.261A22	●		10Nm/30s		●	●		6		1	●			●		●
SQM40.264A21	●		10Nm/30s		●	●		6		4	●			●	●	
SQM40.264R11	●		10Nm/30s		●	●		6		4		●	●		●	
SQM40.265A11	●		10Nm/30s		●	●		6		5	●		●		●	
SQM40.265A21	●		10Nm/30s		●	●		6		5	●			●	●	
SQM40.265R11	●		10Nm/30s		●	●		6		5		●	●		●	
SQM40.265A20	●		10Nm/30s		●	●		6		5	●			●		
SQM40.267A20	●		10Nm/30s		●	●		6		7	●			●		
SQM40.271A20	●		10Nm/30s		●		●	5	1	1	●			●		
SQM40.271R10	●		10Nm/30s		●		●	5	1	1		●	●			
SQM40.274R10	●		10Nm/30s		●		●	5	1	4		●	●			
SQM40.275A20	●		10Nm/30s		●		●	5	1	5	●			●		
SQM40.275A21	●		10Nm/30s		●		●	5	1	5	●			●	●	

**Type summary (cont'd) (other types on request)**

Product no.	Direction of rotation		Torque	PCB						Shaft no.	Regional version		Operating voltage		Potentiometer	
	Counterclockwise	Clockwise		Electronic	Basic	3-position	2-position	Switches	Relay		EU	US	AC120V	AC230V	Single	Double
SQM41.141A21		●	5Nm/15s	●				3		1	●			●	●	
SQM41.144R11		●	5Nm/15s	●				3		4		●	●		●	
SQM41.145A21		●	5Nm/15s	●				3		5	●			●	●	
SQM41.145R11		●	5Nm/15s	●				3		5		●	●		●	
SQM41.164R11		●	5Nm/15s		●	●		6		4		●	●		●	
SQM41.165R11		●	5Nm/15s		●	●		6		5		●	●		●	
SQM41.174R10		●	5Nm/15s		●		●	5	1	4		●	●			
SQM41.241A11		●	10Nm/30s	●				3		1	●		●		●	
SQM41.241R11		●	10Nm/30s	●				3		1		●	●		●	
SQM41.241A21		●	10Nm/30s	●				3		1	●			●	●	
SQM41.244A21		●	10Nm/30s	●				3		4	●			●	●	
SQM41.244R11		●	10Nm/30s	●				3		4		●	●		●	
SQM41.245A11		●	10Nm/30s	●				3		5	●		●		●	
SQM41.245A21		●	10Nm/30s	●				3		5	●			●	●	
SQM41.245R11		●	10Nm/30s	●				3		5		●	●		●	
SQM41.261A11		●	10Nm/30s		●	●		6		1	●		●		●	
SQM41.261R11		●	10Nm/30s		●	●		6		1		●	●		●	
SQM41.261A21		●	10Nm/30s		●	●		6		1	●			●	●	
SQM41.264A21		●	10Nm/30s		●	●		6		4	●			●	●	
SQM41.265R11		●	10Nm/30s		●	●		6		5		●	●		●	
SQM41.267A21		●	10Nm/30s		●	●		6		7	●			●	●	
SQM41.271R10		●	10Nm/30s		●		●	5	1	1		●	●			
SQM41.274R10		●	10Nm/30s		●		●	5	1	4		●	●			
SQM41.275A21		●	10Nm/30s		●		●	5	1	5	●			●	●	



**Note**  
Not all types of actuators are available ex stock. Additional versions are available on request.

**Drive shafts:**

Type of drive shaft	Max. torque	Shaft no.
Ø 10 mm, woodruff key as per DIN 6888	10 Nm	1
□ 9.5 mm, equivalent to drive shaft of Honeywell Mod. III	10 Nm	4
Ø 10 mm D type shaft, compatible with SQM45...	10 Nm	5
Ø 14 mm with parallel key as per DIN 6885, compatible with SQM48...	10 Nm	7



## Accessories

---

- Woodruff key or parallel key
- Connectors depending on the PCB variant

### Front cover (on request)

For making the connections for the power supply lines  
- For 1/2" NPT protective sleeve  
- For metric cable gland

**AGA45.11**  
**AGA45.12**



#### Note

Connecting covers are used depending on the application. The actuators come with the covers prefitted.

### Terminal kits

- For replacement
- For SQM4x.x4x.xxx
- For SQM4x.x6x.xxx and SQM4x.x7x.xxx

**AGA45.4**  
**AGA45.6**

## Technical Data

General unit data	Operating voltage	
	- SQM4x.xxxA1...	AC 120 V -15%/+10%
	- SQM4x.xxxA2...	AC 230 V -15%/+10%
	- SQM4x.xxxR1...	AC 120 V -15%/+10%
	- SQM4x.xxxR2...	AC 230 V -15%/+10%
	Operating frequency	50...60 Hz $\pm$ 6%
	Drive motor	Synchronous motor
	Power consumption	10 VA
	Operating angle	Adjustable between 0 and max. 90°
	Mounting position	Optional
	Degree of protection	IP66/Nema 4
	External overload fuse	Max. 6,3 AT (slow) to DIN EN 60127/2-5
	Cable entry	2 x M16 without thread or 2 x 1/2" NPT thread
	Direction of rotation	Facing the shaft end: counterclockwise or clockwise
	Torque (Holding torque = driving torque x 50%)	5 or 10 Nm, depending on type <sup>1)</sup> For torques refer to nominal operating conditions
	Running time	15 s and 30 s, depending on type <sup>1)</sup>
	End and auxiliary switches	
	- Type	To DIN 41636
	- Switching voltage	AC 24...250 V
	- Switching capacity	1 A, AC 250 V
	Number of end switches	2
	Number of auxiliary switches	Max. 4
	Drive shaft	Supplied as standard, not replaceable
Weight	Approx. 2 kg	

1) At 60 Hz frequency, running times are about 17 % shorter and torques lower by the same rate.

## Analog inputs

<b>General</b>	
Linearity	<5%
Control range	0...90°
<b>Voltage setpoint</b>	
X1-1 (U-IN), X1-2 (GND)	DC 2...10 V
- Umin	DC 2 (0) V
- Umax	DC 10 V
Input impedance	$\geq$ 5 k $\Omega$
<b>Current setpoint</b>	
X1-3 (I-IN), X1-2 (GND)	DC 4...20 mA
- Imin	DC 4 (0) mA
- Imax	DC 20 mA
Input impedance	$\leq$ 500 $\Omega$
<b>Impedance setpoint</b>	
X1-4, X1-5, X1-6 (GND)	0...135 $\Omega$
- RNominal	135 $\Omega$ $\pm$ 5%

**Technical Data** (cont'd)

Conductive plastic potentiometer	Operating voltage	DC 10 V	
	Permissible hysteresis	0,2% of 90° or 135°	
	Total resistance tolerance	±20%	
	Effective angular rotation	90° or 135°	
	Terminal strip	Triple-pole	
	For cross-sectional areas of	0,5...1 mm <sup>2</sup>	
	Wiper current rating	Max. 100 µA	
	Transfer resistance of wiper contact	Max. $R_{ü} \leq 100 \Omega$	
	Linearity (referred to $R_{ges} = 1000 \Omega$ )	±1%	
	Smoothness ( $\alpha = 10^\circ$ ) / microlinearity	<0,1%	
	Life cycle	Approx. 2 million switching cycles	
	<hr/>		
	For use in North America	<b>Cross-sectional area of the power supply lines</b>	
For SQM4x.x6.../SQM4x.x7... (X1)/(X2)/(X3), SQM4x.4... (X2)		Class 1 Min. AWG 16 Suited for 105 °C Max. 2.5 mm <sup>2</sup> or AWG 14	
For SQM4x.x4... (X1)		Class 2 Min. AWG 22 Suited for 105 °C Max. 1 mm <sup>2</sup> or AWG 18	
<hr/>			
<hr/>			
Environmental conditions	<b>Storage</b>	DIN EN 60721-3-1	
	Climatic conditions	Class 1K3	
	Mechanical conditions	Class 1M2	
	Temperature range	-20...60 °C	
	Humidity	<95% r.h.	
	<b>Transport</b>	DIN EN 60721-3-2	
	Climatic conditions	Class 2K3	
	Mechanical conditions	Class 2M2	
	Temperature range	-20...60 °C	
	Humidity	<95% r.h.	
	<b>Operation</b>	DIN EN 60721-3-3	
	Climatic conditions	Class 3K5	
	Mechanical conditions	Class 3M4	
	Temperature range	-20...60 °C	
	Humidity	<95% r.h.	

Connection terminals

SQM4x.x4xxx

Electronic version

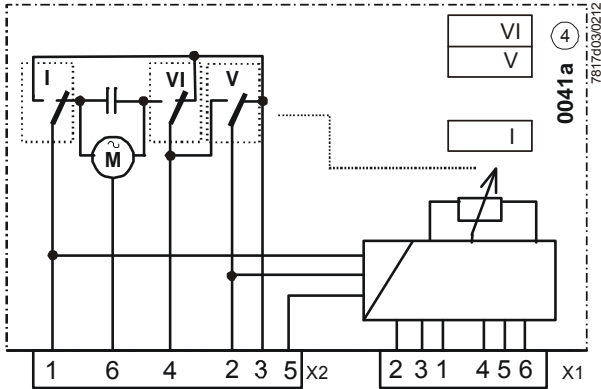

Mains voltage terminals			Design
X2-1	Opening (I)	Input	AC 120 V/AC 230 V
X2-2	Startup in low-fire (V)	Input	AC 120 V/AC 230 V
X2-3	Position reached	Output	AC 120 V/AC 230 V max. 10 mA
X2-4	Closing/ignition (VI)	Input	AC 120 V/AC 230 V
X2-5	Controller release	Input	AC 120 V/AC 230 V
X2-6	Neutral	Input	AC 120 V/AC 230 V
Low-voltage terminals			Design
X1-1	2...10 V input	Input	Max. 10 V to X1-2
X1-2	GND	Input	
X1-3	4...20 mA input	Input	Max. 20 mA to X1-2
X1-4	0...135 Ω 1	Input	
X1-5	0...135 Ω 2	Input	
X1-6	0...135 Ω 3 (GND)	Input	

Range adjustment

Adjust the range of the analog signal to match the switch positions (min. and max. position):

1. Set cam I to the required high-fire position (e.g. 85°; position is indicated on the scale next to the cam).
2. Set cam V to the required low-fire position (e.g. 20°).
3. Preset the signal at the analog input according to the required high-fire position (e.g. 20 mA).
4. Turn the potentiometer for maximum angular rotation
  - a) clockwise, if the actuator has not yet reached its maximum angular rotation, or
  - b) counterclockwise until the actuator starts
5. Preset the signal at the analog input according to the low-fire position (e.g. 4 mA).
6. Turn the potentiometer for minimum angular rotation
  - a) counterclockwise, if the actuator has not yet reached its minimum angular rotation, or
  - b) clockwise until the actuator starts

Modulation always takes place between high- and low-fire.

Also, it is possible to define a closed position or a separate ignition position by setting cam VI (independent of cam V, e.g. for defining a position higher than the low-fire position).

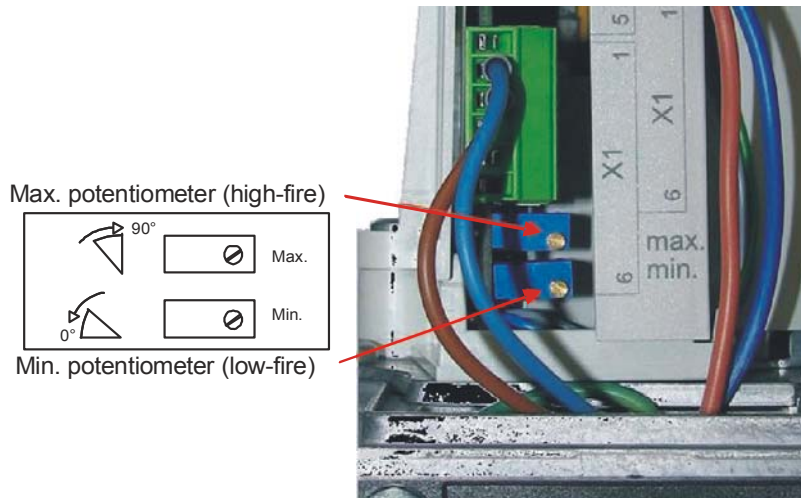

7817z08e/1109

Connection terminals (cont'd)

SQM4x.x6xxx

3-position version with 2 end switches and 4 auxiliary switches

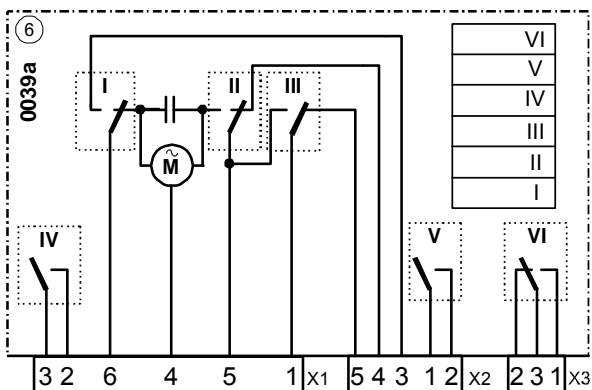

Mains voltage terminals			Design
X3-1	AUX (VI) NO	Output	AC 120 V/AC 230 V max. 1 A
X3-2	AUX (VI) NC	Output	AC 120 V/AC 230 V max. 1 A
X3-3	AUX (VI)	Input	AC 120 V/AC 230 V
X2-1	AUX (V)	Input	AC 120 V/AC 230 V
X2-2	AUX (V) NO	Output	AC 120 V/AC 230 V max. 1 A
X2-3	Open position reached	Output	AC 120 V/AC 230 V max. 1 A
X2-4	Closed position reached	Output	AC 120 V/AC 230 V max. 1 A
X2-5	Ignition position reached	Output	AC 120 V/AC 230 V max. 1 A
X1-1	Startup in ignition position	Input	AC 120 V/AC 230 V
X1-2	AUX (IV) NO	Output	AC 120 V/AC 230 V max. 1 A
X1-3	AUX (IV)	Input	AC 120 V/AC 230 V
X1-4	Neutral		
X1-5	Closing	Input	AC 120 V/AC 230 V
X1-6	Opening	Input	AC 120 V/AC 230 V

SQM4x.x7xxxx

2-position version with 2 end switches and 3 auxiliary switches

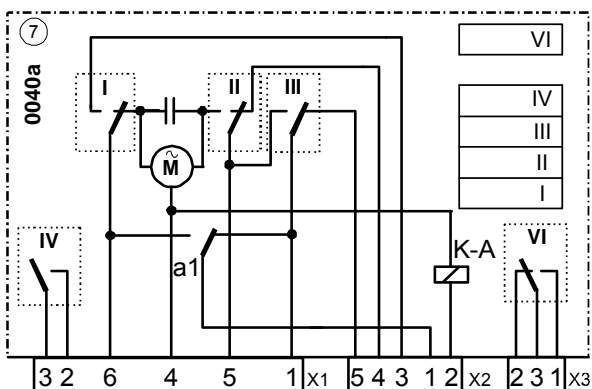

Mains voltage terminals			Design
X3-1	AUX (VI) NO	Output	AC 120 V/AC 230 V max. 1 A
X3-2	AUX (VI) NC	Output	AC 120 V/AC 230 V max. 1 A
X3-3	AUX (VI)	Input	AC 120 V/AC 230 V
X2-1	Mains voltage	Input	AC 120 V/AC 230 V
X2-2	Opening/closing (changeover switch)	Input	AC 120 V/AC 230 V
X2-3	Open position reached	Output	AC 120 V/AC 230 V max. 1 A
X2-4	Closed position reached	Output	AC 120 V/AC 230 V max. 1 A
X2-5	Ignition position reached	Output	AC 120 V/AC 230 V max. 1 A
X1-1	Startup in ignition position	Input	AC 120 V/AC 230 V
X1-2	AUX (IV) NO	Output	AC 120 V/AC 230 V max. 1 A
X1-3	AUX (IV)	Input	AC 120 V/AC 230 V
X1-4	Neutral		
X1-5	Closing	Input	AC 120 V/AC 230 V
X1-6	Opening	Input	AC 120 V/AC 230 V

Example for SQM40... (CCW)

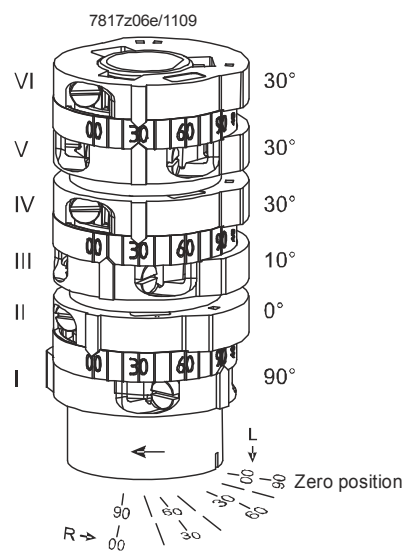

Example for SQM41... (CW)

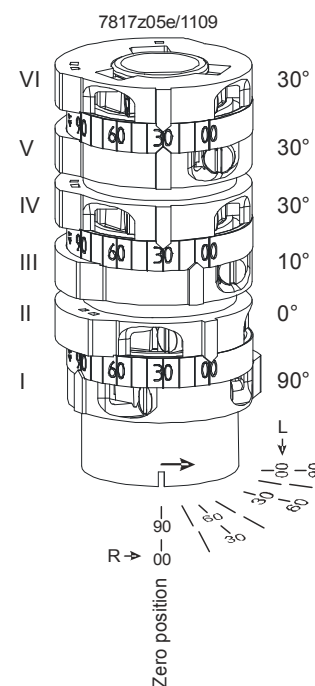

**Note!**  
The setting of the switch position must be checked.

SQM4x.x4...

Electronic version		Preadjustment
Cam I	High-fire	90°
Cam II	Not used	---
Cam III	Not used	---
Cam IV	Not used	---
Cam V	Low-fire	10°
Cam VI	OFF/ignition	0°

SQM4x.x6...

3-position version		Preadjustment
Cam I	High-fire	90°
Cam II	OFF/low-fire	0°
Cam III	Ignition position	10°
Cam IV	Auxiliary switch	30°
Cam V	Auxiliary switch	30°
Cam VI	Auxiliary switch	30°

SQM4x.x7...

2-position version		Preadjustment
Cam I	High-fire	90°
Cam II	OFF/low-fire	0°
Cam III	Ignition position	10°
Cam IV	Auxiliary switch	30°
Cam V	Not used	---
Cam VI	Auxiliary switch	30°

# Dimensions

Dimensions in mm

SQM40.../SQM41...

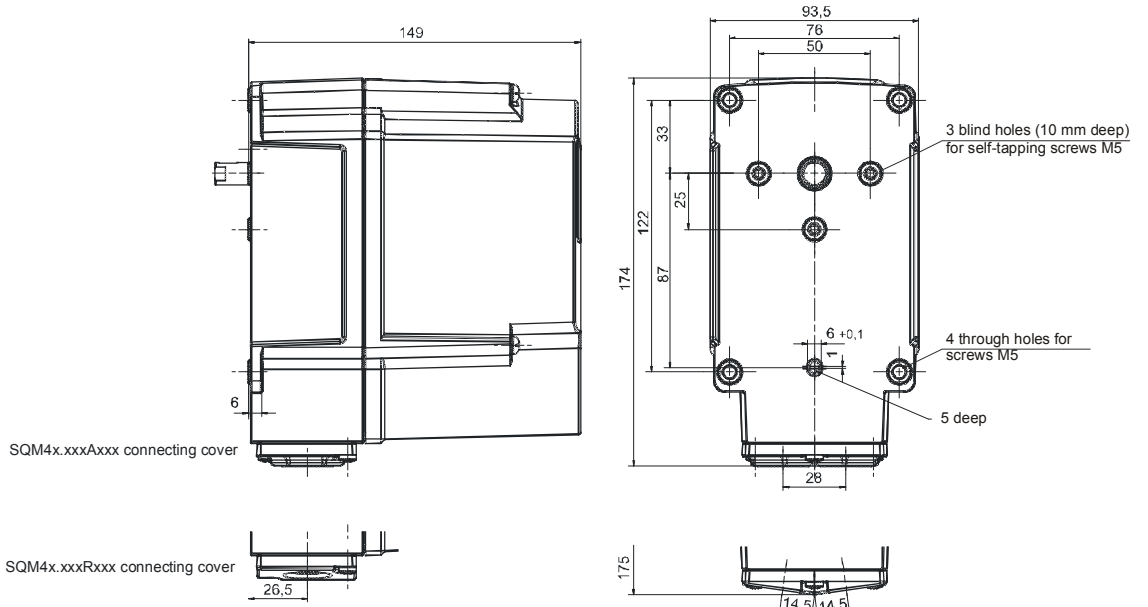

			Shaft no.
SQM4x.xx1xxx	Slot for woodruff key 3x3.7 series A Din6888		1
SQM4x.xx4xxx	Square		4
SQM4x.xx5xxx	D-shaft		5
SQM4x.xx7xxx	Slot for parallel key A5x3x28 DIN6885 T3		7

7817m01e/0312