



Symaro™

## Duct Sensor

## QFM4160

for relative humidity and temperature  
with calibration certificates

- **Operating voltage AC 24 V or DC 13.5...35 V**
- **Signal output DC 0...10 V for relative humidity and temperature**
- **Very high measuring accuracy throughout the entire measuring range**
- **Capacitive humidity measurement**
- **Recalibration service**

### Use

The QFM4160 sensor is used in ventilation and air conditioning plants requiring:

- Very high accuracy and reliability for measuring relative humidity and temperature
- Regular recalibration and readjustment of the sensors

Examples:

- Storage and production facilities in the paper, textiles, pharmaceutical, chemical, electronics industries, etc.
- Laboratories
- Hospitals
- Computer centers
- Greenhouses

## Ordering and delivery

When ordering, please give name and type reference:

Room sensor **QFM4160**

The circular connector with its screwed plug is delivered uninstalled.

## Equipment combinations

The QFM4160 is for use with all types of systems and devices that can acquire and handle the sensor's DC 0...10 V output signal.

## Technical design

### Relative humidity

The sensor acquires relative humidity via its capacitive sensing element whose capacitance varies as a function of the relative humidity of the ambient air.

An electronic circuit converts the sensor's signal to a continuous DC 0...10 V signal, corresponding to a relative humidity of 0...100 %.

### Temperature

The sensor acquires the temperature via its sensing element whose electrical resistance varies according to the temperature of the ambient air.

This variation is converted to an active DC 0...10 V output signal, corresponding to a temperature range of 0...50 °C, -35...+35 °C, or 0...70 °C. The measuring range can be selected.

## Ausführung

The duct sensor consists of housing, printed circuit board, connection terminals, immersion rod with measuring probe and circular connector. The housing consists of 2 parts: Base and removable cover (screwed).

A rubber seal is installed between the housing and cover in order to satisfy the requirements of IP 65 degree of protection.

The measuring circuit and the setting element are accommodated on the printed circuit board inside the cover the connection terminals on the base.

The sensing elements are located at the end of the measuring probe, protected by a screw-on filter cap.

Cable entry is made via the circular connector, which consists of coupling piece with M16 thread and screwed plug. The coupling piece is secured to the housing and internally wired.

Immersion rod and housing are made of plastic and rigidly connected.

The sensor is designed for screwed or flanged mounting. It can be fitted as follows:

- With the mounting flange supplied with the sensor (recommended), which is to be fitted to the sensor and then secured in accordance with the required immersion length, or
- Without mounting flange (making use of the maximum immersion length). For that propose, the housing has 4 holes for fitting the sensor directly to the air duct

### Setting element

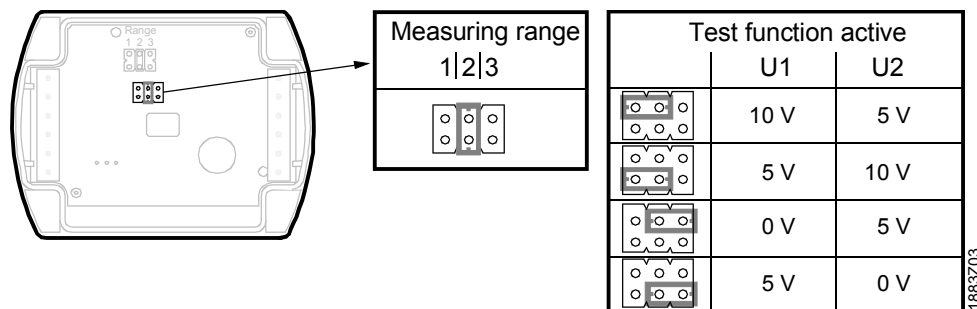

The setting element is located inside the cover. It consists of 6 pins and a shorting plug. It is used for selecting the required temperature measuring range and for activating the test function.

The different shorting plug positions have the following meaning:

- *For the active temperature measuring range:*  
 Shorting plug in the left position (R1) = -35...+35 °C,  
 Shorting plug in the mid position (R2) = 0...50 °C (factory setting)  
 Shorting plug in the right position (R3) = 0...70 °C
  - *For the active test function:*  
 Shorting plug in the horizontal position: The values available at the signal output are those given in the table "Test function active"
- Behavior in the event of fault
- If the temperature sensor is faulty, the voltage at signal output U2 is 0 V and the humidity signal at signal output U1 increases to 10 V
  - If the humidity sensor is faulty, the voltage at signal output U1 is 10 V after 60 seconds; the temperature signal remains active

Calibration certificates

The sensor and its exchangeable AQF4150 measuring tip are numbered, registered and calibrated prior to delivery. The associated calibration certificates are supplied with the sensor.

## Accessories

<i>Name</i>	<i>Type reference</i>
Measuring tip (exchangeable)	<b>AQF4150</b>
Filter cap (for replacement)	<b>AQF3101</b>

## Engineering notes

To power the sensor, a transformer for safety extra low-voltage (SELV) with separate windings for 100 % duty is required. When sizing and protecting the transformer, the local safety regulations must be observed.

When sizing the transformer, the power consumption of the duct sensor must be taken into consideration.

For correct wiring of the sensor, refer to the Data Sheets of the devices with which the sensor is used.

The permissible line lengths must be observed.

Cable routing and cable selection

When laying the cables, it must be observed that the longer the cables run side by side and the smaller the distance between them, the greater the electrical interference.

Shielded cables must be used in environments with EMC problems.

Twisted pair cables are required for the secondary supply lines and the signal lines.

## Mounting notes

Location

The sensor should be mounted in the middle of the duct wall. If used in connection with steam humidifiers, the minimum distance after the humidifier should be 3 m, the maximum distance 10 m.

If the application involves dew point shifting, the sensor must be fitted in the extract air duct.

Only the flange must be fitted to the duct wall. The sensor is then inserted through the flange and engaged.

*Caution!*

- The seal between housing and cover must not be removed, or else degree of protection IP 65 will be no longer ensured.
- The measuring rod's sensing elements are sensitive to impact. Avoid any such impact on mounting.

Fitting instructions

Mounting Instructions are printed on the inner side of the package.

## Commissioning notes

---

Check wiring before switching on power. The temperature measuring range must be selected on the sensor, if required.

## Recalibration service

---

SBT HVAC Products provides a recalibration service for used sensors. The recalibration should be performed at 12-month intervals under "normal" conditions, i.e. within the comfort range for humidity and temperature, and at air contamination levels that are not above average.

### Services provided

The recalibration service includes the following:

- Delivery and invoicing of the new AQF4150 measuring tip complete with calibration certificate
- Delivery of a calibration certificate for the (old) measuring tip returned to SBT HVAC Products, enabling the customer to assess the time of usage of the measuring tip

## Technical data

---

Power supply	Operating voltage	AC 24 V $\pm$ 20 % or DC 13.5...35 V
	Frequency	50/60 Hz
	Power consumption	$\leq$ 1 VA
Cable lengths for the measuring signal U1, U2	Max. perm. cable lengths	
	Copper cable 0.6 mm dia.	50 m
	Copper cable 1 mm <sup>2</sup>	150 m
Copper cable 1.5 mm <sup>2</sup>	300 m	
Functional data "Humidity sensor"	Measuring range	0...100 % r. h.
	Measuring accuracy at 23 °C 0...100 % r. h.	$\pm$ 2 %
	Temperature dependency	$\leq$ 0.05 % r. h./°C
	Time constant	approx. 20 s in moving air
	Output signal, linear (terminal U1)	DC 0...10 V $\hat{=}$ 0...100 % r. h., $\pm$ 1 mA max.
	Functional data "Temperature sensor"	Measuring range
Sensing element		Pt 1000 class B
Measuring accuracy in the range of 15...35 °C -35...+70 °C		$\pm$ 0.6 K $\pm$ 0.8 K
Time constant		approx. 20 s in moving air
Output signal, linear (terminal U2)		DC 0...10 V $\hat{=}$ 0...50 °C / -35...+35 °C / 0...70 °C max. $\pm$ 1 mA
Degree of protection		Housing
	Safety class	III to EN 60 730
Electrical connections	Connector with screwed plug	Lumberg RSC 4/9
	Screw terminals for	0.75 mm <sup>2</sup> max.
	Cable entry	4...8 mm dia.

Environmental conditions	Operation to	IEC 721-3-3
	Climatic conditions	class 4K2
	Temperature (housing with electronics)	-40...+70 °C
	Humidity	0...100 % r. h. (with condensation)
Materials and colors	Mechanical conditions	class 3M2
	Transport to	IEC 721-3-2
	Climatic condition	class 2K3
	Temperature	-25...+70 °C
	Humidity	<95 % r. h.
	Mechanical conditions	class 2M2
	Base	polycarbonate, RAL 7001 (silver-grey)
	Cover	polycarbonate, RAL 7035 (light-grey)
	Immersion rod	polycarbonate, RAL 7001 (silver-grey)
	Filter cap	polycarbonate, RAL 7001 (silver-grey)
Standards	Mounting flange	PA 66 (black)
	Circular connector	
	Connector with screwed plug	Lumberg RSC 4/9
	Contact carrier and body	PA, black
	Knurled nut and contact	CuZn, nickel-plated
	Coupling piece	Lumberg RKFM 4/0,5 M
	Contact carrier	TPU
	Casing and contact	CuZn, nickel-plated
	Sensor (complete assembly)	silicon-free
	Packaging	corrugated cardboard
Weight	Product safety	
	Automatic electrical controls for household and similar use	EN 60 730-1
	Electromagnetic compatibility	
	Emissions	EN 61 000-6-1
	Immunity	EN 61 000-6-3
	CE conformity to	EMC directive 89/336/EEC
Weight	☑ conformity to	
	Australian EMC framework	Radio Communication Act 1992
	Radio Interference Emission Standard	AS/NZS 3548
Weight	Incl. packaging	0.244 kg

## Connection terminals

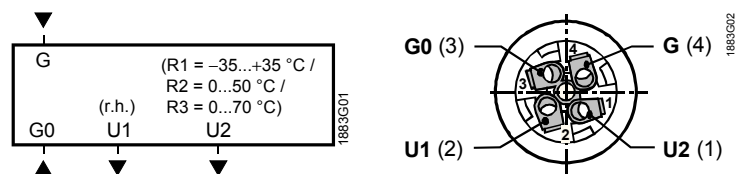

Front view:  
Connector fitted,  
body removed

- G, G0 Operating voltage AC 24 V (SELV) or DC 13,5...35 V
- U1 Signal output DC 0...10 V for relative humidity 0...100 %
- U2 Signal output DC 0...10 V for temperature 0...50 °C (R2 = factory setting) or -35...+35 °C (R1) or 0...70 °C (R3)

# Dimensions

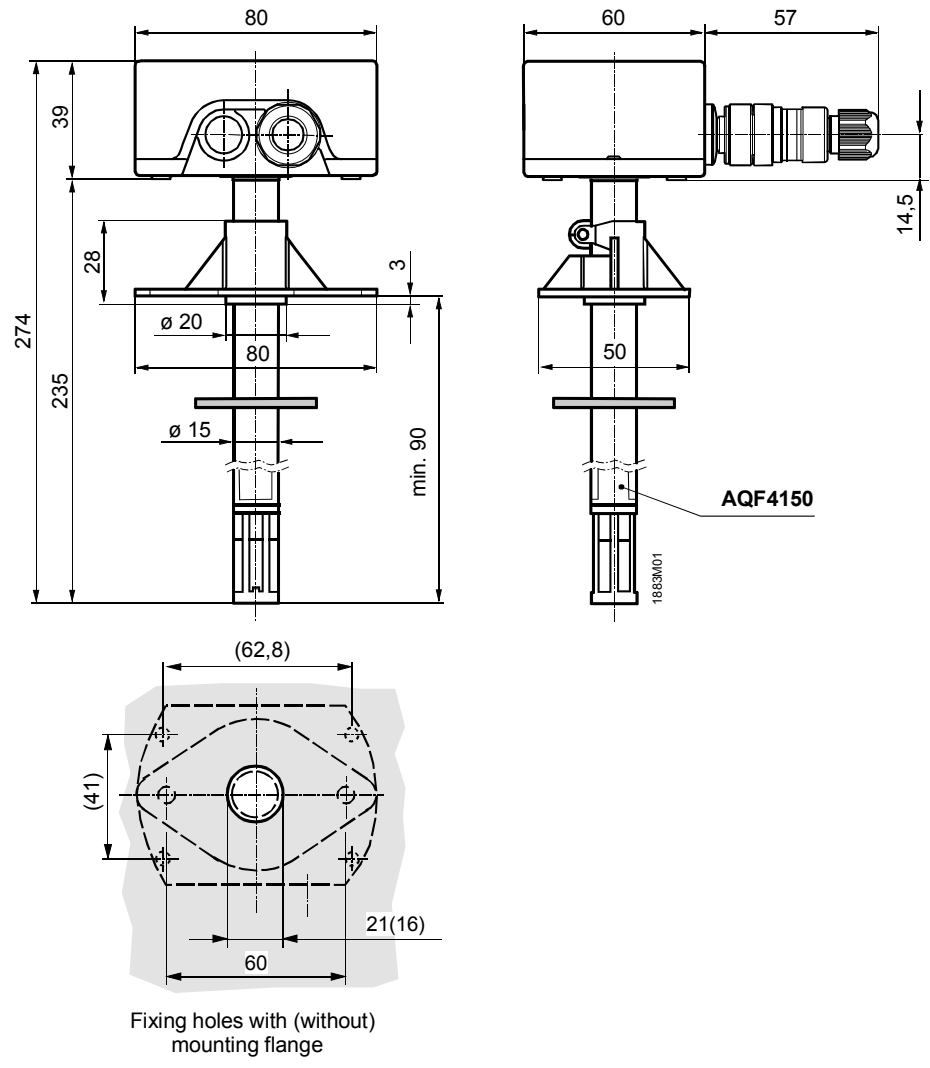

Dimensions in mm