

Control Module Box AP 118

5WG1 118-4AB01

Product- and Applications Description



The AP 118 Control Module Box with a height of 41 mm is designed for installation in a false ceiling, in a raised floor, directly on a wall or in an installation channel or raceway. The Control Module Box is affixed with screws at the two ends of the housing.

The Control Module Box offers one mounting location for these modules:

5WG1 260-4AB23	Binary input, quadruple, AC/DC 12...230V
5WG1 510-2AB23	Binary output (relay), 2 x 10A
5WG1 512-4AB23	Load switch (relay), 1 x 16A
5WG1 520-2AB23	Blind / shutter actuator, 1 x 6A
5WG1 521-4AB23	Blind / shutter actuator, 2 x 6A
5WG1 525-2AB23	Universal dimmer, 1 x 250VA

The mounted module is connected to the bus line via a bus terminal block.

The AP 118 Control Module Box provides wiring space with room for two connectors for PE and N conductors. This allows for secure connection of the PE and N conductors of the cables inserted into the AP 118 Control Module Box.

For strain relief, cables can be secured at the entrance to the wiring space.

Line voltage supply and load conductors are terminated at the terminals of the mounted modules.

Application Programs

Requires no application programs

Example of Application

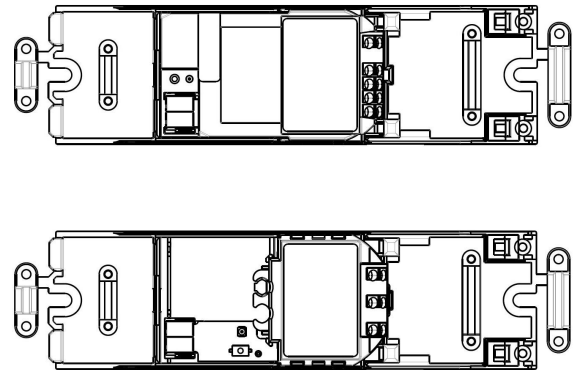

figure 1: Example of Application

Installation instructions

- The Control Module Box may be used for permanent interior installations, for mounting in dry rooms, in false ceilings, raised floors, and installation channels or raceways.



DANGER

- The Control Module Box must be mounted and commissioned by an authorized electrician.
- A safety disconnection of the Control Module Box must be possible.
- For planning and construction of electric installations, the relevant guidelines, regulations and standards of the respective country are to be considered.

Technical Data

Physical Specifications

- housing: plastic
- dimensions:
Length x Width x Height (in mm): 180 x 50 x 41,1
- weight: approx. 100g
- fire load: approx. 3000 kJ
- mounting: with two screws
- one mounting location for RS / RL modules

Connections

- Bus line: screwless bus connection block (red-black)
0.6...0.8 mm Ø single core, strip insulation 5mm
- Mains power: 230 V AC \pm 10 %, 50...60 Hz
terminals of RS / RL modules

Electrical Safety

- Degree of pollution (according to IEC 60664-1): 2
- Type of protection (according to EN 60529): IP 20
- Overvoltage category (according to IEC 60664-1): III
- Bus: safety extra low voltage SELV DC 24 V

Environmental specifications

- Climatic withstand capability: EN 50090-2-2
- Ambient temperature operating: - 5 ... + 45 °C
- Ambient temperature non-op.: - 25 ... + 70 °C
- relative humidity (non-condensing): 5 % bis 93 %

CE norm

- complies with low voltage regulations

Mounting and Connecting

General description

The Control Module Box is designed for on-surface mounting on ceilings, walls, on the floor or any even surface, as well as installation in installation channels or raceways. The holes for screw fastening of the Control Module Box are located on the ends of the box and are accessible after opening the housing. The Control Module Box is affixed with two screws.

Mounting

- Mounting of the Control Module Box:
 - Distance between drill holes for screw fastening: 166 mm (see figure 2-a)
 - Pull the latching clamp (A4) away from the lid (A5), lift the lid up, swivel it up and remove it from the hinge (A6).
 - Fix the Control Module Box at the fixation points (A2) (see figure 2-b) with screws (e.g. 4.5 x 50 mm, to be sourced separately).

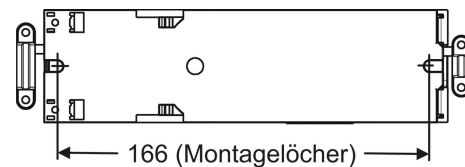

figure 2a: Mounting

Control Module Box AP 118

5WG1 118-4AB01

- A1 Product label
- A2 Hole for screw fastening of Control Module Box
- A3 Screws for securing the lid
- A4 Latching clamp for locking the lid
- A5 Control Module Box, Lid
- A6 Hinge for lid
- A7 Bushing for BUS cables (with strain relief)
- A8 Bushing for low voltage cables (with strain relief)
- A9 Control Module Box, base
- A10 Bus terminal
- A11 Mounting location for one RS / RL module
- A12 RS module (to be ordered separately)
- A13 RL module (to be ordered separately)
- A14 Clamp for strain relief (cut off from base)

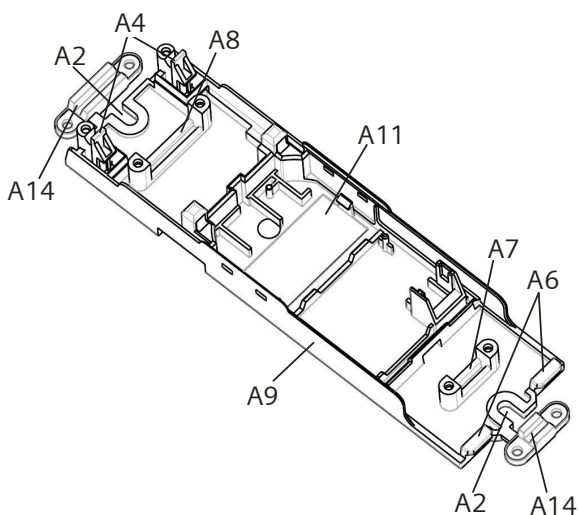

figure 2b: Mounting

- Removing the lid of the Control Module Box:
 - Remove the screws (A3) securing the lid.
 - Pull the latching clamp (A4) away from the lid (A5), lift the lid up, swivel it up and remove it from the hinge (A6).
- Mounting the lid of the Control Module Box:
 - Hook the lid (A5) into the hinge (A6).
 - Push the lid (A5) down until it audibly snaps into the latching clamp (A4).
 - Fasten the screws (A3) to secure the lid.

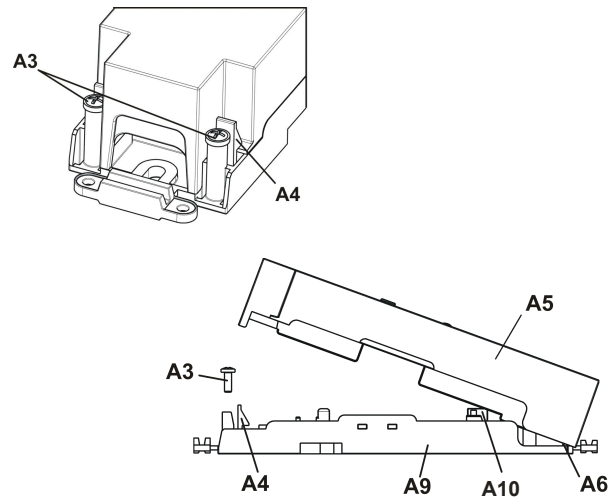

figure 3: Removing/Mounting the lid of the Control Module Box

- Mounting / Dismounting of RS /RL modules:

A RS module (A13) or an RL module (A14) may be installed at the mounting location (A12) of the Control Module Box. Mounting of the RS and RL modules is described generically in these mounting and operating instructions.

Notes on wiring and commissioning of specific modules may be found in the respective documentation for that module.

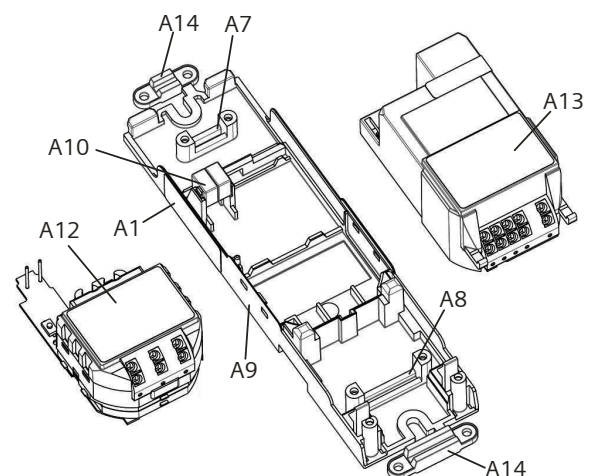

figure 4: mounting / dismounting of RS/RL modules

Mounting of RS / RL modules

- B1 RS module
- B2 RL module
- B3 Type label (with space for physical address of the module)
- B4 Mounting location for RS / RL module in AP 118 Control Module Box or AP 641 Room Control Box
- B5 Bus connection module with bus connection pins for bus terminal block, LED for indicating normal operating mode (LED off) or addressing mode (LED on), Learning button and contacts to RS module
- B6 Insertion point for bus connection module of the RS module
- B7 Snap-in point for bus connection module of the RS module
- B8 Learning button for switching between normal operating mode and addressing mode and for receiving the physical address
- B9 LED for indicating normal operating mode (LED off) or addressing mode (LED on); returns to normal operating mode automatically after receiving the physical address
- B10 Bus connection pins of the module for connection of the bus terminal block in the respective mounting location
- B11 Insertion point for bus terminal
- B12 Bus connection block for single core conductors with 0,6...0,8 mm Ø
- B13 Hinge joint for mounting hinge of the RL module
- B14 Terminals

• Mounting of a RS module:

- AP 118: Remove the lid of the Control Module Box.
- Insert the bus connection module (B5) in such a way into the insertion point (B6) for the bus connection module that the bus connection pins (B10) point to the insertion point for the bus terminal (B11).
- Press the bus connection module (B5) down until it snaps into the locking position (B7).
- Insert the RS module (B1) from the top with the terminals (B14) pointing away from the bus terminal insertion point (B11). The type label (B3) is on top.
- Insert the bus terminal (B12) of the mounting location (B4) onto the bus connection pins (B10) of the bus connection module (B5).
- For assignment of the Physical Address press the learning button (B8) for a maximum of 2 seconds. The addressing mode is indicated when the LED is on (B9). It returns to normal operating mode (LED Off) automatically after receiving the physical address.
- Mount the lid again.

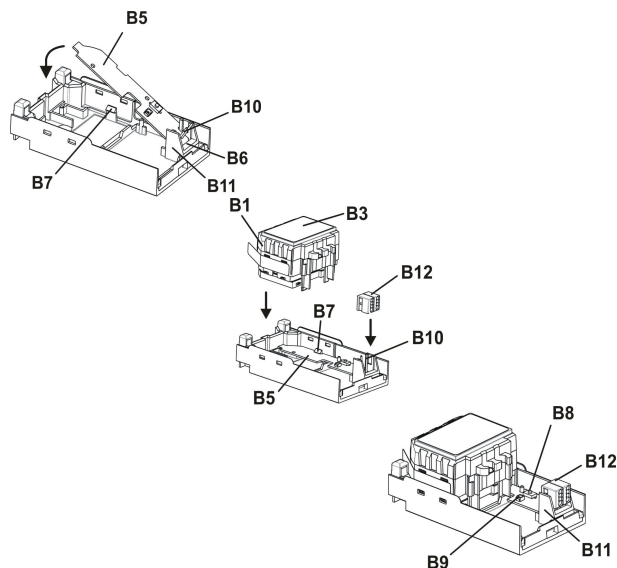
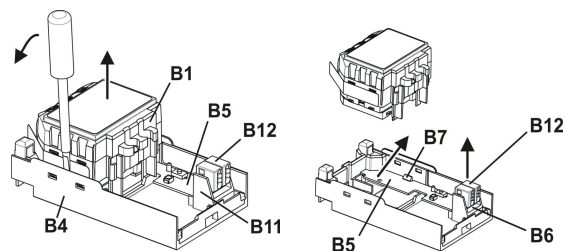

figure 5: mounting of a RS module

• Dismounting an RS module:

- AP 118: Remove the lid of the Control Module Box.
- Remove the wiring from the terminals (B14).
- Remove the bus terminal (B12).
- To remove the RS module (B1), insert a screw driver between the module and the mounting location siding and push it up to release it from the snap-in hooks. Do this on both sides.
- Pull the RS module (B1) from the mounting location (B4).
- If an RL module (B2) shall be inserted into the mounting location, detach the bus connection module (B5) from the snap-in point (B7), swivel it up and pull it out of the insertion point (B6). Mount the lid again.



Control Module Box AP 118

SWG1 118-4AB01

figure 6: dismantling an RS module

- Mounting of an RL module:

- AP 118: Remove the lid of the Control Module Box.
- Insert the RL module (B2) into the hinge (B13) of the mounting location (B4). The terminals (B14) point away from the insertion point for the bus terminal (B11). The type label (B3) is on top.
- Swivel the RL module (B2) down until it audibly snaps into the mounting location (B4).
- Insert the bus terminal (B12) of the mounting location (B4) onto the bus connection pins (B10) of the RL module (B2).
- For assignment of the Physical Address press the learning button (B8) for a maximum of 2 seconds. The addressing mode is indicated when the LED is on (B9). It returns to normal operating mode (LED Off) automatically after receiving the physical address.
- Mount the lid again.

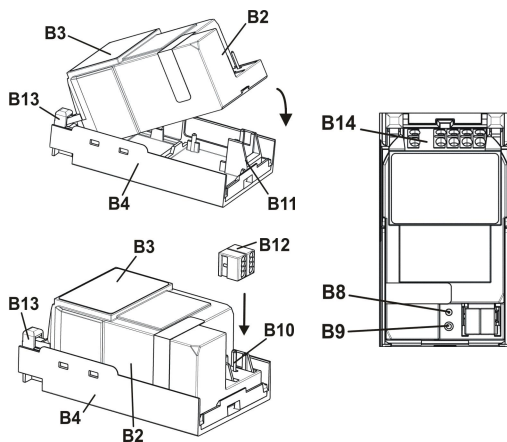

figure 7: mounting of an RL module

- Dismounting an RL module:

- AP 118: Remove the lid of the Control Module Box.
- Remove the wiring from the terminals (B14).
- Remove the bus terminal (B12).
- To remove the RL module (B2), insert a screw driver between the module and the mounting location on the bus terminal side and push it up to release it from the snap-in hooks.
- Swivel the RL module (B2) up, pull it down out of the hinge (B13) and remove it from the mounting location (B4).
- Mount the lid again.

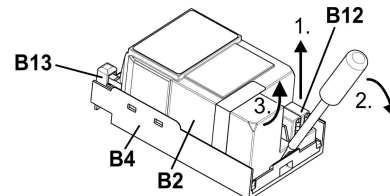

figure 8: dismantling an RL module

WiringSlipping off/on bus connection blocks

The bus connection block (C2) is situated on the back of the actuator (C1).

It consists of two components (C2.1 and C2.2) with four terminal contacts each. Take care not to damage the two test sockets (C2.3) by accidentally connecting them to the bus cable or with the screw driver (e.g. when attempting to unplug the bus connection block).

Slipping off bus connection blocks

- Carefully put the screw driver to the wire insertion slit of the bus connection block's grey component (C2.2) and
- pull the bus connection block (C2) from the module .

Note

Don't try to remove the bus connection block from the bottom side. There is a risk of shorting-out the device!

Slipping on bus connection blocks

- Slip the bus connection block (C2) onto the guide slot of the module and
- press the bus connection block (C2) down to the stop.

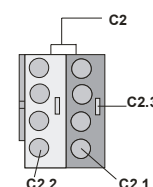

figure 9: Slipping off/on bus connection blocks

Connecting bus cables

- The bus connection block (D1) can be used with single core conductors $\varnothing 0.6...0.8$ mm.
- Remove approx. 5 mm of insulation from the conductor (D2) and plug it into the bus connection block (D1) (red = +, grey = -)

Disconnecting bus cables

- Unplug the bus connection block (D1) and remove the bus cable conductor (D2) while simultaneously wiggling it.

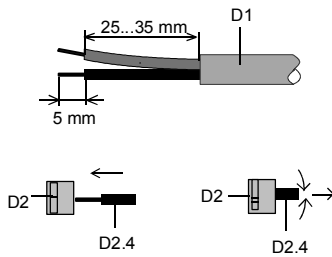

figure 10: Connecting / Disconnecting bus cables

Connecting/disconnecting mains and load circuit:

Connect wires

- The load circuits are connected via screwless plug-in terminals (E1).
- Remove approx. 9...10 mm of insulation from the wire (E 1.1) and plug it into the terminal (E1).
- The terminals are designed for connection of two wires allowing to loop through the terminal block.

Note:

The maximum permissible terminal load current is 16A.

Remove wires

- Press the terminal interlocking of the terminal (F1) with a screw-driver and remove the wire (F2) from the terminal (F1).

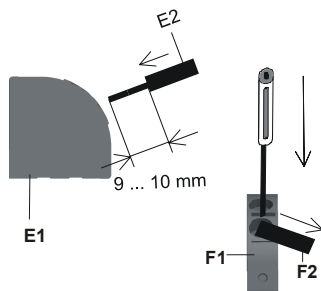
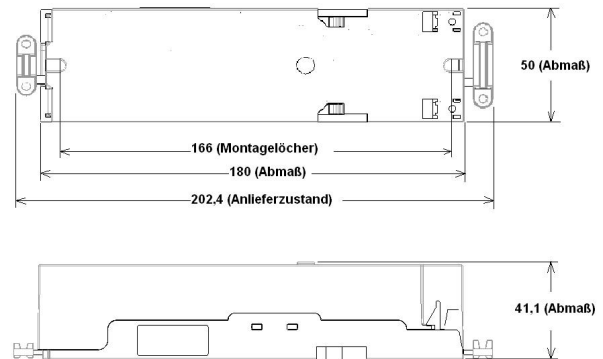

figure 11: Connecting/disconnecting mains and load circuit

Dimension drawing

Dimension in mm



General Notes

- The operating instructions must be handed over to the client.
- Any faulty device is to be sent together with a return delivery note of the local Siemens office.
- For any technical questions, please consult:
 - ☎ +49 (911) 895-7222
 - ☎ +49 (911) 895-7223
 - ✉ support.automation@siemens.com
 - www.siemens.com/automation/support-request