

GB Light oil burners

Progressive two-stage or modulating operation

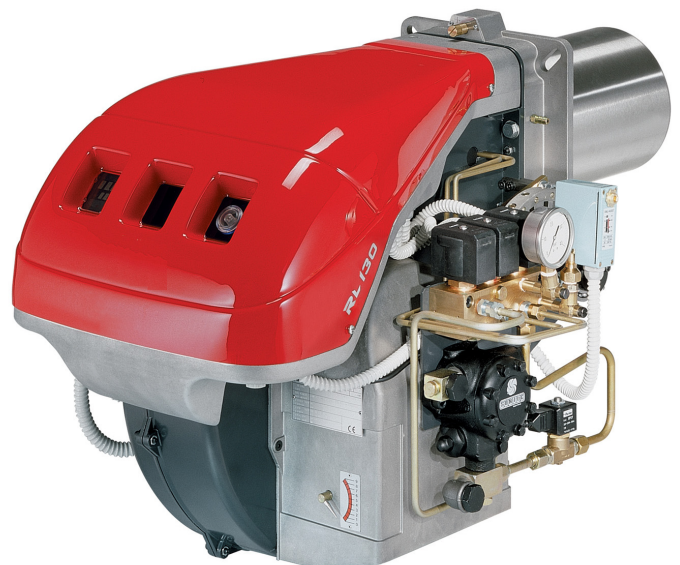

| CODE | MODEL | TYPE |
|----------|----------|--------|
| 20166463 | RL 70/M | 669 T1 |
| 20166476 | RL 70/M | 669 T1 |
| 20166481 | RL 100/M | 670 T1 |
| 20166484 | RL 100/M | 670 T1 |
| 20166486 | RL 130/M | 671 T1 |
| 20166487 | RL 130/M | 671 T1 |



Translation of the original instructions

| | | |
|-----------|---|-----------|
| 1 | Declarations | 2 |
| 2 | Information and general warnings | 3 |
| 2.1 | Information about the instruction manual | 3 |
| 2.2 | Guarantee and responsibility | 4 |
| 3 | Safety and prevention | 5 |
| 3.1 | Introduction | 5 |
| 3.2 | Personnel training | 5 |
| 4 | Technical description of the burner | 6 |
| 4.1 | Burner designation | 6 |
| 4.2 | Models available | 6 |
| 5 | Technical description of the burner | 7 |
| 5.1 | Technical data | 7 |
| 5.2 | Electrical data | 7 |
| 5.3 | Maximum dimensions | 8 |
| 5.4 | Standard equipment | 8 |
| 5.5 | Firing rates | 9 |
| 5.6 | Test boiler | 9 |
| 5.7 | Burner description | 10 |
| 5.8 | Electrical panel description | 11 |
| 5.9 | Control box RFGO-A22 | 12 |
| 5.10 | Servomotor (SQN31...) | 13 |
| 6 | Installation | 14 |
| 6.1 | Notes on safety for the installation | 14 |
| 6.2 | Handling | 14 |
| 6.3 | Preliminary checks | 14 |
| 6.4 | Operating position | 15 |
| 6.5 | Boiler plate | 15 |
| 6.6 | Blast tube length | 15 |
| 6.7 | Securing the burner to the boiler | 16 |
| 6.8 | Electrode positions | 16 |
| 6.9 | Nozzle installation | 17 |
| 6.10 | Nozzle assembly | 17 |
| 6.11 | Combustion head setting | 18 |
| 6.12 | Light oil supply | 19 |
| 6.13 | Pump | 21 |
| 6.14 | Electrical connections | 22 |
| 6.15 | Calibration of the thermal relay | 23 |
| 6.16 | Motor rotation | 23 |
| 7 | Start-up, calibration and operation of the burner | 24 |
| 7.1 | Notes on safety for the first start-up | 24 |
| 7.2 | Burner firing | 24 |
| 7.3 | Operation | 24 |
| 7.4 | Pressure switch adjustment | 27 |
| 7.5 | Operation sequence of the burner | 28 |
| 7.6 | Final checks | 28 |
| 8 | Maintenance | 29 |
| 8.1 | Notes on safety for the maintenance | 29 |
| 8.2 | Maintenance programme | 29 |
| 8.3 | Opening the burner | 31 |
| 8.4 | Closing the burner | 31 |
| 9 | LED indicator and special function | 32 |
| 9.1 | Description of LED lamps | 32 |
| 9.2 | Check mode function | 32 |
| 9.3 | Flame control lock-out or emergency stop condition | 32 |
| 9.4 | LED lamps: burner operating status | 33 |
| 10 | Problems - Causes - Remedies signalled by LED indicators | 34 |

1 Declarations

| Declaration of conformity in accordance with ISO / IEC 17050-1 | | | |
|--|--|-------------------------------|--|
| Manufacturer: | RIELLO S.p.A. | | |
| Address: | Via Pilade Riello, 7 37045 Legnago (VR) | | |
| Product: | Light oil burners | | |
| Model and type: | RL 70/M | 669 T1 | |
| | RL 100/M | 670 T1 | |
| | RL 130/M | 671 T1 | |
| These products are in compliance with the following Technical Standards: | | | |
| EN 267 | | | |
| EN 12100 | | | |
| and according to the European Directives: | | | |
| MD | 2006/42/EC | Machine Directive | |
| LVD | 2014/35/EU | Low Voltage Directive | |
| EMC | 2014/30/EU | Electromagnetic Compatibility | |

The quality is guaranteed by a quality and management system certified in accordance with ISO 9001:2015.

| Manufacturer's Declaration | | | |
|--|--------|----------|-------------|
| RIELLO S.p.A. declares that the following products comply with the NOx emission limits specified by German standard "1. BImSchV release 26.01.2010". | | | |
| Product | Type | Model | Power |
| Light oil burner | 669 T1 | RL 70/M | 261-1043 kW |
| | 670 T1 | RL 100/M | 332-1482 kW |
| | 671 T1 | RL 130/M | 498-1779 kW |

Legnago, 01.12.2015

Executive General Manager
RIELLO S.p.A. - Burner Department

Mr. U. Ferretti



Research & Development Director
RIELLO S.p.A. - Burner Department

Mr. F. Comencini



2 Information and general warnings

2.1 Information about the instruction manual

2.1.1 Introduction

The instruction manual supplied with the burner:

- is an integral and essential part of the product and must not be separated from it; it must therefore be kept carefully for any necessary consultation and must accompany the burner even if it is transferred to another owner or user, or to another system. If the manual is lost or damaged, another copy must be requested from the Technical Assistance Centre of the area;
- is designed for use by qualified personnel;
- offers important indications and instructions relating to the installation safety, start-up, use and maintenance of the burner.

Symbols used in the manual

In some parts of the manual you will see triangular DANGER signs. Pay great attention to these, as they indicate a situation of potential danger.

2.1.2 General dangers

The **dangers** can be of **3 levels**, as indicated below.



Maximum danger level!
This symbol indicates operations which, if not carried out correctly, cause serious injury, death or long-term health risks.



This symbol indicates operations which, if not carried out correctly, may cause serious injury, death or long-term health risks.



This symbol indicates operations which, if not carried out correctly, may cause damage to the machine and/or injury to people.

2.1.3 Other symbols



DANGER: LIVE COMPONENTS
This symbol indicates operations which, if not carried out correctly, lead to electric shocks with lethal consequences.



DANGER: FLAMMABLE MATERIAL
This symbol indicates the presence of flammable materials.



DANGER: BURNING
This symbol indicates the risks of burns due to high temperatures.



DANGER: CRUSHING OF LIMBS
This symbol indicates the presence of moving parts: danger of crushing of limbs.



WARNING: MOVING PARTS

This symbol indicates that you must keep limbs away from moving mechanical parts; danger of crushing.



DANGER: EXPLOSION

This symbol signals places where an explosive atmosphere may be present. An explosive atmosphere is defined as a mixture - under atmospheric conditions - of air and flammable substances in the form of gases, vapours, mist or dust in which, after ignition has occurred, combustion spreads to the entire unburned mixture.



PERSONAL PROTECTION EQUIPMENT

These symbols indicate the equipment that must be worn and kept by the operator for protection against threats against safety and/or health while at work.



OBLIGATION TO ASSEMBLE THE COVER AND ALL THE SAFETY AND PROTECTION DEVICES

This symbol signals the obligation to reassemble the cover and all the safety and protection devices of the burner after any maintenance, cleaning or checking operations.



ENVIRONMENTAL PROTECTION

This symbol gives indications for the use of the machine with respect for the environment.



IMPORTANT INFORMATION

This symbol indicates important information that you must bear in mind.

- This symbol indicates a list.

Abbreviations used

| | |
|------|---------|
| Ch. | Chapter |
| Fig. | Figure |
| Page | Page |
| Sec. | Section |
| Tab. | Table |

2.1.4 Delivery of the system and the instruction manual

When the system is delivered, it is important that:

- the instruction manual is delivered to the user by the system manufacturer, with the recommendation to keep it in the room where the heat generator is to be installed.
- The instruction manual shows:
 - the serial number of the burner;

.....

- the address and telephone number of the nearest Assistance Centre

.....

- The system supplier must carefully inform the user about:
 - the use of the system;
 - any further tests that may be required before activating the system;
 - maintenance, and the need to have the system checked at least once a year by a representative of the manufacturer or another specialised technician.
 To ensure a periodic check, the manufacturer recommends the drawing up of a Maintenance Contract.

2.2 Guarantee and responsibility

The manufacturer guarantees its new products from the date of installation, in accordance with the regulations in force and/or the sales contract. At the moment of the first start-up, check that the burner is integral and complete.



WARNING

Failure to observe the information given in this manual, operating negligence, incorrect installation and carrying out of non authorised modifications will result in the annulment by the manufacturer of the guarantee that it supplies with the burner.

In particular, the rights to the guarantee and the responsibility will no longer be valid, in the event of damage to things or injury to people, if such damage/injury was due to any of the following causes:

- incorrect installation, start-up, use and maintenance of the burner;
- improper, incorrect or unreasonable use of the burner;
- intervention of unqualified personnel;
- carrying out of unauthorised modifications on the equipment;
- use of the burner with safety devices that are faulty, incorrectly applied and/or not working;
- installation of untested supplementary components on the burner;
- powering of the burner with unsuitable fuels;
- faults in the fuel supply system;
- continuation of use of the burner when a fault has occurred;
- repairs and/or overhauls incorrectly carried out;
- modification of the combustion chamber with inserts that prevent the regular development of the structurally established flame;
- insufficient and inappropriate surveillance and care of those burner components most likely to be subject to wear and tear;
- use of non-original components, including spare parts, kits, accessories and optional;
- force majeure.

The manufacturer furthermore declines any and every responsibility for the failure to observe the contents of this manual.

3 Safety and prevention

3.1 Introduction

The burners have been designed and built in compliance with current regulations and directives, applying the known safety technical rules and envisaging all the potential danger situations.

It is necessary, however, to bear in mind that the imprudent and clumsy use of the equipment may lead to situations of death risk for the user or third parties, as well as the damaging of the burner or other items. Inattention, thoughtlessness and excessive confidence often cause accidents; the same applies to tiredness and sleepiness.

It is a good idea to remember the following:

- The burner must only be used as expressly described. Any other use should be considered improper and therefore dangerous.

Specifically:

it can be applied to boilers operating with water, steam, diathermic oil, and to other uses expressly named by the manufacturer;

the type and pressure of the fuel, the voltage and frequency of the electrical power supply, the minimum and maximum deliveries for which the burner has been regulated, the pressurisation of the combustion chamber, the dimensions of the combustion chamber and the ambient temperature must all be within the values indicated in the instruction manual.

- Modification of the burner to alter its performance and destinations is not allowed.
- The burner must be used in exemplary technical safety conditions. Any disturbances that could compromise safety must be quickly eliminated.
- Opening or tampering with the burner components is not allowed, apart from the parts requiring maintenance.
- Only those parts envisaged by the manufacturer can be replaced.



The manufacturer guarantees safety and proper functioning only if all burner components are intact and positioned correctly.

3.2 Personnel training

The user is the person, body or company that has acquired the machine and intends to use it for the specific purpose. He is responsible for the machine and for the training of the people working around it.

The user:

- undertakes to entrust the machine exclusively to suitably trained and qualified personnel;
- undertakes to inform his personnel in a suitable way about the application and observance of the safety instructions. With that aim, the user undertakes to ensure that everyone knows the use and safety instructions for his own duties;
- Personnel must observe all the danger and caution indications shown on the machine.
- Personnel must not carry out, on their own initiative, operations or interventions that are not within their province.
- Personnel must inform their superiors of every problem or dangerous situation that may arise.
- The assembly of parts of other makes, or any modifications, can alter the characteristics of the machine and hence compromise operating safety. The manufacturer therefore declines any and every responsibility for any damage that may be caused by the use of non-original parts.

In addition:



- must take all the measures necessary to prevent unauthorised people gaining access to the machine;
- the user must inform the manufacturer if faults or malfunctioning of the accident prevention systems are noticed, along with any presumed danger situation;
- personnel must always use the personal protective equipment envisaged by legislation and follow the indications given in this manual.

4 Technical description of the burner

4.1 Burner designation

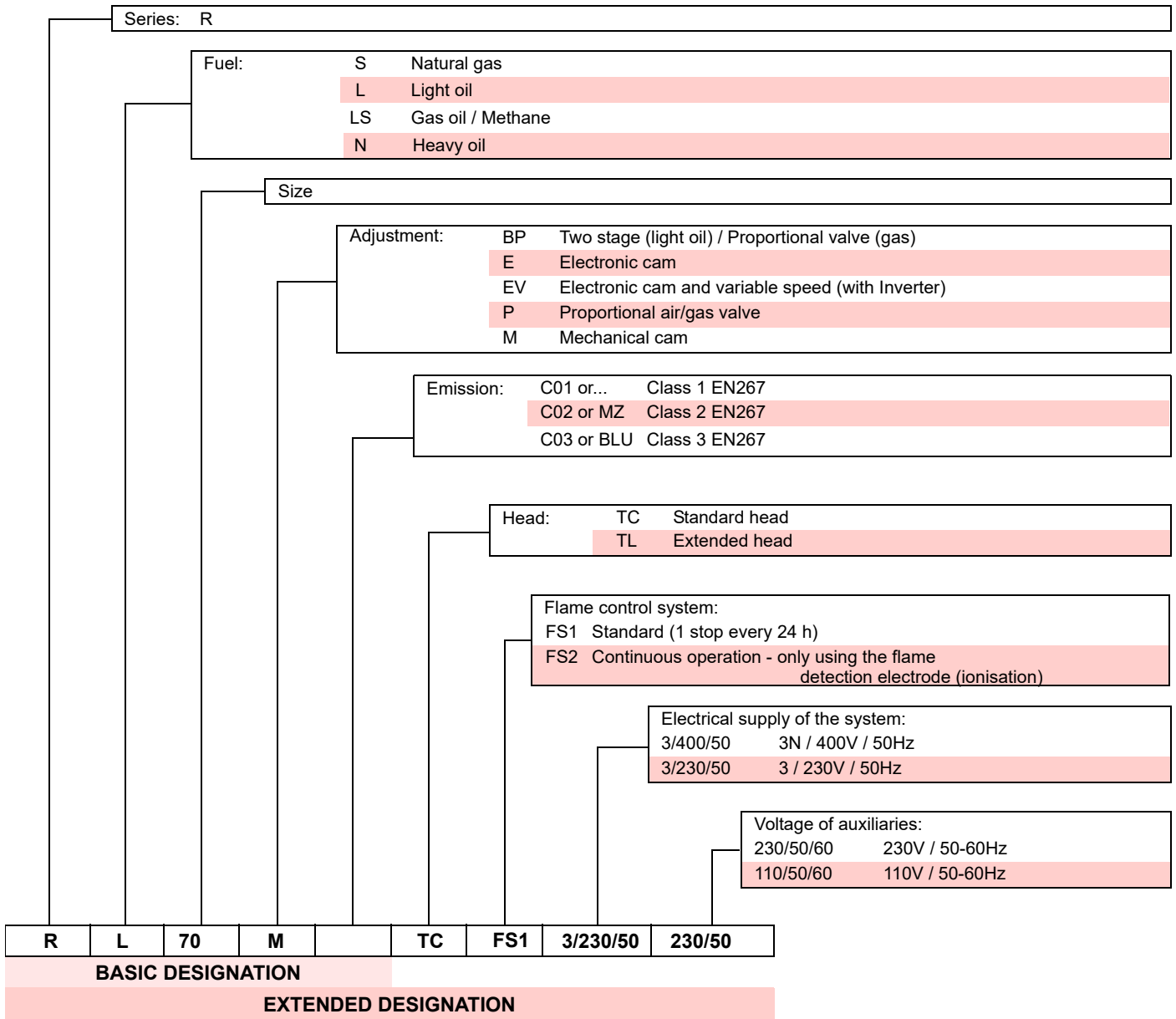

4.2 Models available

| Designation | | | | Voltage | Start-up | Code |
|-------------|----|--|-----|--------------|----------|----------|
| RL 70/M | TC | | FS1 | 3/230-400/50 | Direct | 20166463 |
| RL 70/M | TL | | FS1 | 3/230-400/50 | Direct | 20166476 |
| RL 100/M | TC | | FS1 | 3/230-400/50 | Direct | 20166481 |
| RL 100/M | TL | | FS1 | 3/230-400/50 | Direct | 20166484 |
| RL 130/M | TC | | FS1 | 3/230-400/50 | Direct | 20166486 |
| RL 130/M | TL | | FS1 | 3/230-400/50 | Direct | 20166487 |

5 Technical description of the burner

5.1 Technical data

| MODEL | | | RL 70/M | RL 100/M | RL 130/M |
|-----------------------------|------|--------------------|---|------------|------------|
| Type | | | 669 T1 | 670 T1 | 671 T1 |
| Output (1) | MAX. | kW | 474 - 1043 | 711 - 1482 | 948 - 1779 |
| | | Mcal/h | 408 - 897 | 612 - 1275 | 816 - 1530 |
| | | kg/h | 40 - 88 | 60 - 125 | 80 - 150 |
| | MIN. | kW | 261 - 474 | 332 - 711 | 498 - 948 |
| | | Mcal/h | 224 - 408 | 286 - 612 | 428 - 816 |
| | | kg/h | 22 - 40 | 28 - 60 | 42 - 80 |
| Fuel | | | Light oil | | |
| - net calorific value | | kWh/kg | 11.8 | | |
| | | Mcal/kg | 10.2 (10.200 kcal/kg) | | |
| - density | | kg/dm ³ | 0.82 - 0.85 | | |
| - viscosity at 20 °C | | mm ² /s | max 6 (1.5 °E - 6 cSt) | | |
| Operation | | | <ul style="list-style-type: none"> • Intermittent (min. 1 stop in 24 hours) • Progressive two-stage (modulating by Kit) | | |
| Nozzle | | number | 1 (nozzle with return) | | |
| Standard applications | | | Boilers: water, steam, diathermic oil | | |
| Ambient temperature | | °C | 0 - 40 | | |
| Combustion air temperature | | °C max | 60 | | |
| Pump delivery (at 20 bar) | | kg/h | 190 | | |
| pressure range | | bar | 10 - 21 | | |
| fuel temperature | | °C max | 90 | | |
| Electrical protection | | | IP 44 | | |
| Noise levels ⁽²⁾ | | | | | |
| Sound pressure | | dBA | 75 | 77 | 78.5 |
| Sound power | | | 86 | 88 | 89.5 |

Tab. A

- (1) Reference conditions: Ambient temperature 20°C - Barometric pressure 1000 mbar - Altitude 100 m a.s.l.
 (2) Sound pressure measured in manufacturer's combustion laboratory, with burner operating on test boiler and at maximum rated output. The sound power is measured with the "Free Field" method, as per EN 15036, and according to an "Accuracy: Category 3" measuring accuracy, as set out in EN ISO 3746.

5.2 Electrical data

| MODEL | | RL 70/M | RL 100/M | RL 130/M |
|------------------------------|--|---------|--------------------|----------|
| ELECTRICAL SUPPLY | | V | 230 - 400 ~ +/-10% | |
| | | Hz | 50 - three-phase | |
| ELECTRIC MOTOR | | rpm | 2880 | 2910 |
| | | kW | 1.1 | 1.8 |
| | | V | 230/400 | 230/400 |
| | | A | 4.3/2.5 | 6.9/4 |
| IGNITION TRANSFORMER | | V1 - V2 | 230 V - 2 x 5 kV | |
| | | I1 - I2 | 1.9 A - 30 mA | |
| ELECTRICAL POWER CONSUMPTION | | kW max | 1.7 | 2.5 |
| | | | | 2.85 |

Tab. B

5.2.1 Weight - approximate measurements

The weight of the burner complete with its packaging is shown in table (Tab. C)

| Model | kg |
|----------|----|
| RL 70/M | 65 |
| RL 100/M | 68 |
| RL 130/M | 76 |

Tab. C

5.3 Maximum dimensions

The maximum dimensions of the burner are given in (Fig. 1).

The dimensions of the open burner are indicated by position I.

Bear in mind that inspection of the combustion head requires the burner to be opened and the rear part withdrawn on the slide bars.

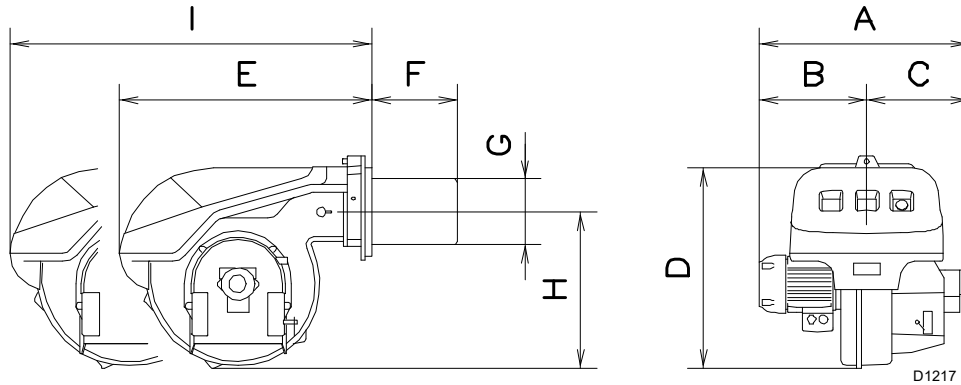

Fig. 1

| mm | A | B | C | D | E | F ⁽¹⁾ | G | H | I ⁽¹⁾ |
|----------|-----|-----|-----|-----|-----|------------------|-----|-----|------------------|
| RL 70/M | 663 | 296 | 367 | 555 | 680 | 272 - 385 | 179 | 430 | 951 - 1086 |
| RL 100/M | 690 | 312 | 367 | 555 | 680 | 272 - 385 | 179 | 430 | 951 - 1086 |
| RL 130/M | 705 | 338 | 367 | 555 | 680 | 272 - 385 | 189 | 430 | 951 - 1086 |

⁽¹⁾ Blast tube: short-long

Tab. D

5.4 Standard equipment

| | |
|---|-------|
| Flexible hoses | No. 2 |
| Gaskets for flexible hoses | No. 2 |
| Nipples for flexible hoses | No. 2 |
| Thermal insulation screen | No. 1 |
| Extensions 17) for slide bars 14) (for models with 385 mm blast tube) | No. 4 |
| Screws to secure the burner flange to the boiler: M 12 x 35 | No. 4 |
| Manual | No. 1 |
| Spare part list | No. 1 |

5.5 Firing rates

During operation, burner output varies between:

- **MINIMUM OUTPUT:** area A;
- **MAXIMUM OUTPUT:** area B (and C for model RL 130/M).

Graphs (Fig. 2):

Horizontal axis : Burner output

Vertical axis : Combustion chamber pressure

The work point may be found by plotting a vertical line from the desired delivery and a horizontal line from the pressure in the combustion chamber. The intersection of these two lines is the work point which must lie within area A, for MIN output, and within area B, for MAX output.

In order to utilize also area C (RL 130/M) it is necessary to perform the calibration of the combustion head as explained on page 16.



WARNING

The FIRING RATE area values have been obtained considering a surrounding temperature of 20 °C, and an atmospheric pressure of 1000 mbar (approx. 100 m above sea level) and with the combustion head adjusted as shown on page 18.

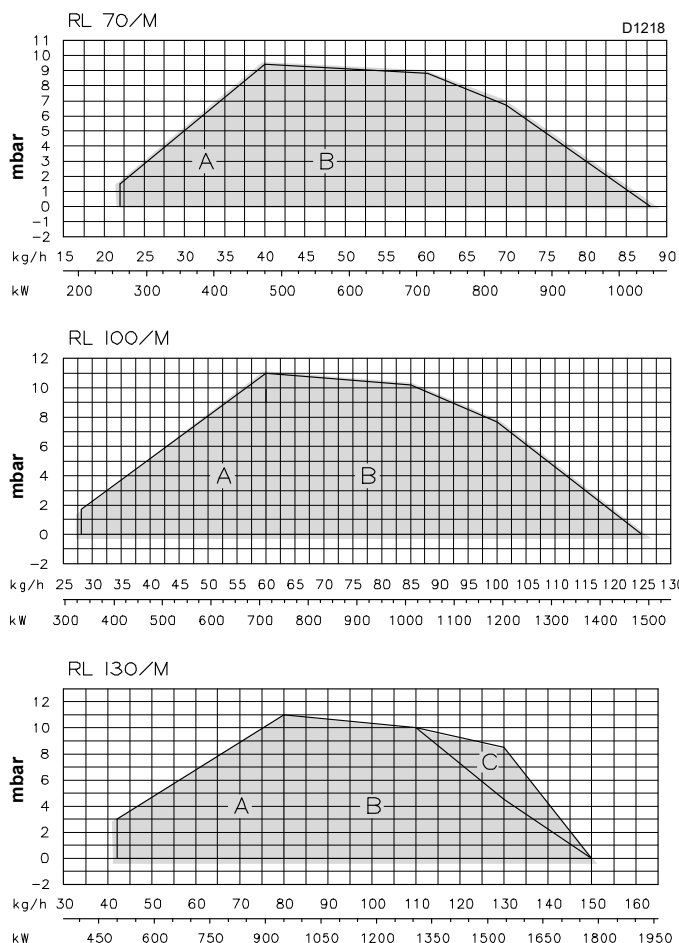

Fig. 2

5.6 Test boiler

The burner/boiler combination does not pose any problems if the boiler is EC approved and its combustion chamber dimensions are similar to those indicated in the diagram (Fig. 3).

If the burner must be combined with a boiler that has not been EC approved and/or its combustion chamber dimensions are clearly smaller than those indicated in the diagram, consult the manufacturer.

The firing rates were obtained in special test boilers, according to EN 676 regulations.

In Fig. 3 you can see the diameter and length of the test combustion chamber.

Example:

Output 650 Mcal/h (407 kW): diameter 60 cm - length 2 m.

MODULATING RATIO

The modulating ratio, obtained in test boilers, according to standard (EN 267 for light oil), is of 4:1 for light oil.

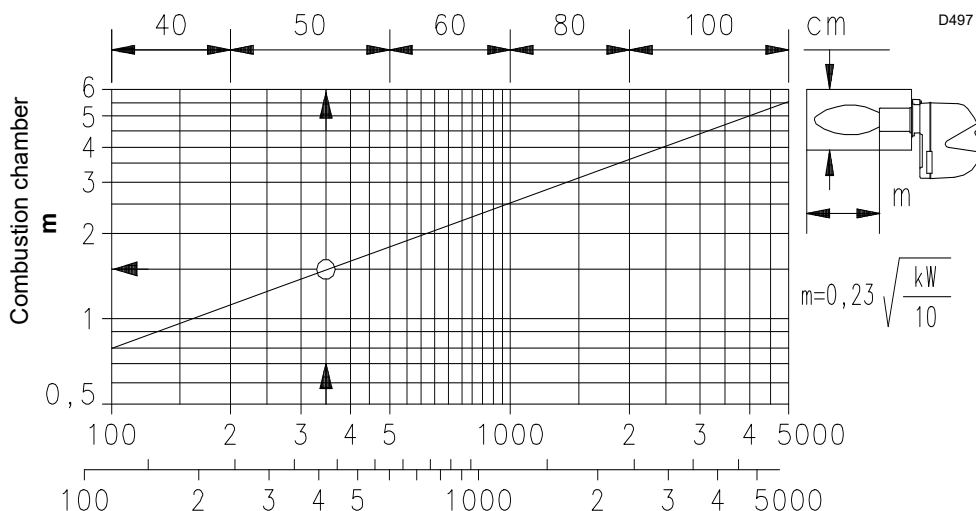

Fig. 3

5.7 Burner description

- 1 Ignition electrodes
- 2 Combustion head
- 3 Screw for combustion head adjustment
- 4 Screw for fixing fan to flange
- 5 Oil pressure switch
- 6 Pressure gauge for pressure on nozzle return
- 7 Pump
- 8 Nozzle holder
- 9 Air gate valve
- 10 Fan pressure test point
- 11 Boiler mounting flange
- 12 Flame stability disk
- 13 Servomotor, provides adjustment of fuel delivery regulator and of air gate valve.

When the burner is not operating the air gate valve is fully closed in order to reduce to a minimum heat dispersion from the boiler due to the flue draught which draws air from the fan suction inlet.

- 14 Slide bars for opening the burner and inspecting the combustion head
- 15 Electrical motor
- 16 Extensions for slide bars 14)
- 17 Control box
- 18 Flame inspection window
- 19 Valve assembly with pressure regulator on nozzle return

Two types of burner failure may occur:

Control Box Lock-out: if the control box 17) push-button lights up, it indicates that the burner is in lock-out.

To reset, press the push-button of the thermal relay 3)(Fig. 5 on page 11).

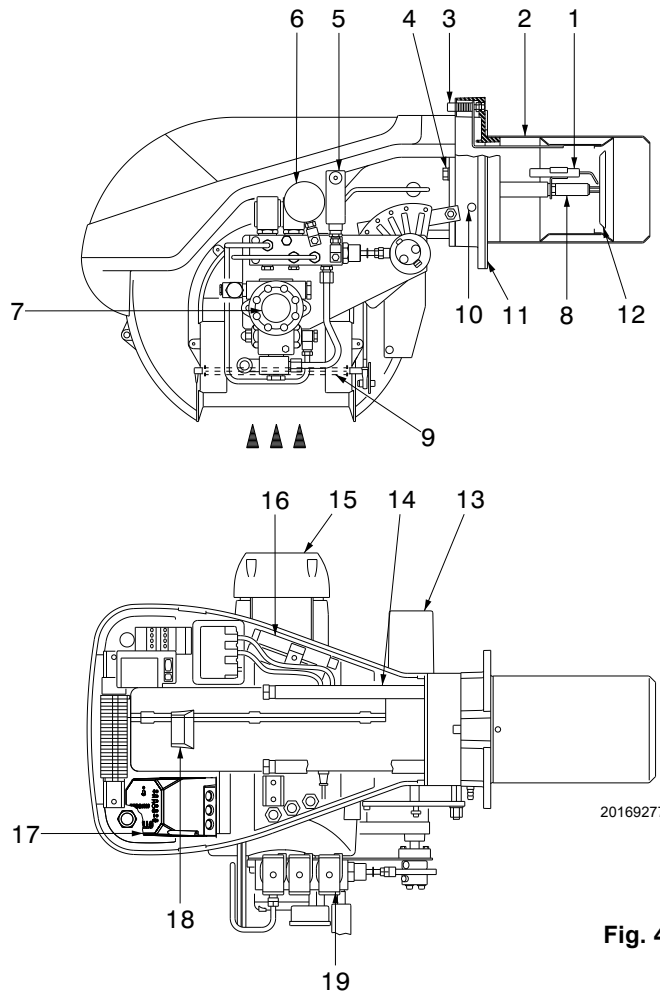
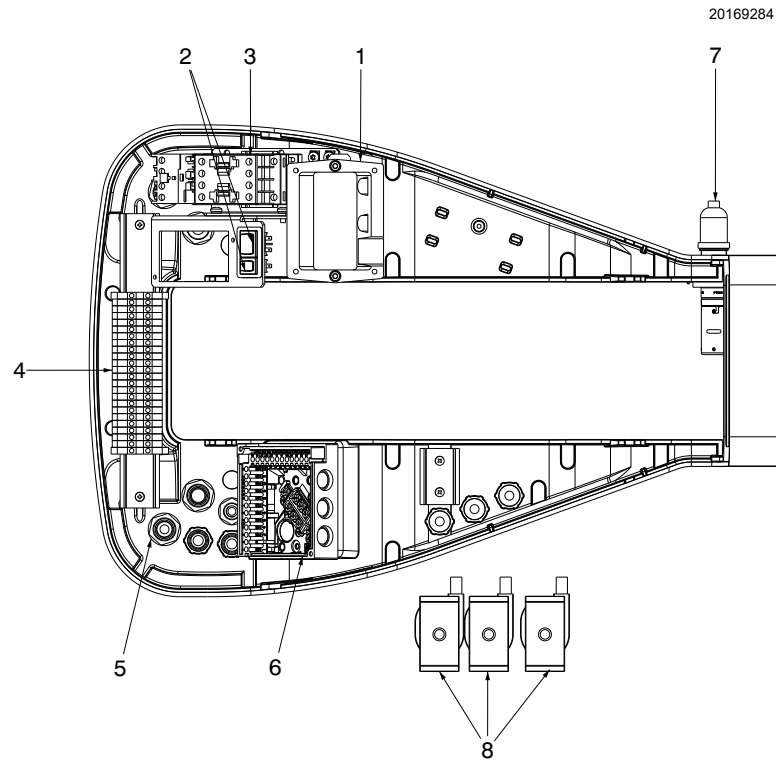

Fig. 4

5.8 Electrical panel description



- 1 Ignition transformer
- 2 A switch for:
automatic-manual-OFF operation
A button for:
increase - decrease output
- 3 Motor contactor and thermal relay with reset button
- 4 Terminal board for electrical connection
- 5 Cable-grommets for external connections to be carried out
by the installer
- 6 Control box base
- 7 Flame sensor
- 8 Coil for oil valves

Fig. 5

5.9 Control box RFGO-A22

Important notes



To avoid accidents, material or environmental damage, observe the following instructions!

The control box is a safety device! Avoid opening or modifying it, or forcing its operation. The Manufacturer cannot assume any responsibility for damage resulting from unauthorised work!

- All interventions (assembly and installation operations, assistance, etc.) must be carried out by qualified personnel.
- Before modifying the wiring in the control box connection area, fully disconnect the system from the power supply (omnipolar separation).
- Protection against electrocution from the control box and all connected electric components is obtained with the correct assembly.
- Before any intervention (assembly and installation operations, assistance, etc.), ensure the wiring is in order and that the parameters are correctly set, then make the safety checks.
- Falls and collisions can negatively affect the safety functions. In this case, the control box must not be operated, even if it displays no evident damage.

For safety and reliability, comply with the following instructions:

- avoid conditions that can favour the development of condensate and humidity. Otherwise, before switching on again, make sure that the entire control box is perfectly dry!
- Static charges must be avoided since they can damage the control box's electronic components when touched.

Use

The control box is a control and supervision system of medium and large capacity forced draught burners.

If used with the flame detection electrode the system can operate continuously whereas, with the use of UV sensors it operates intermittently with stop and restart request at least once every 24h.

Installation notes

- Make sure that the electrical wiring inside the boiler complies with national and local safety regulations.
- Do not confuse the powered conductors with the neutral ones.
- Ensure that spliced wires cannot get into contact with neighbouring terminals. Use adequate ferrules.
- Arrange the H.V. ignition cables separately, as far as possible from the control box and the other cables.
- When wiring the unit, make sure that AC 230 V mains voltage cables are run strictly separate from extra low-voltage cables to avoid risks of electrical shock hazard.



Fig. 6

Technical data

| | |
|--------------------------|------------------------------|
| Mains voltage | AC 230 V -15% / +10% |
| Mains frequency | 50 / 60 Hz |
| Primary fuse (external) | Refer to the electric system |
| Weight | approx. 1.1 kg |
| Power absorption | approx. AC 7 VA |
| Protection level | IP40 |
| Safety class | II |
| Environmental conditions | |
| Operation | DIN EN 60721-3-1 |
| Climatic conditions | Class 1K2 |
| Mechanical conditions | Class 1M2 |
| Temperature range | -50...+85°C |
| Humidity | < 90% RH (non-condensing) |

Tab. E

Electrical wiring of the flame detector

It is important for signal transmission to be almost totally free of any disturbances or loss:

- Always separate the detector cables from the other cables:
 - The capacitive reactance of the line reduces the size of the flame signal.
 - Use a separate cable.
- Respect the allowed cable lengths.
- The ionisation probe is not protected against the risk of electrocution. When connected to the electricity supply, the ionisation probe must be protected against any accidental contact.
- Position the ignition electrode and the ionisation probe so that the ignition spark cannot form an arc on the probe (risk of electric overcharge).

5.10 Servomotor (SQN31...)

Important notes



To avoid accidents, material or environmental damage, observe the following instructions!

Avoid opening, modifying or forcing the actuators.

- All interventions (assembly and installation operations, assistance, etc.) must be carried out by qualified personnel.
- Before modifying the wiring in the connection area of the servomotor, fully disconnect the burner control device from the power supply (omnipolar separation).
- To avoid the risk of electrocution, protect the connection terminals in a suitable manner and correctly fix the cover.
- Check the wiring is in order.
- Falls and collisions can negatively affect the safety functions. In this case, the servomotor must not be operated, even if it displays no evident damage.

Assembly notes

- Check the relevant national safety standards are respected.
- When assembling the servomotor and connecting the damper, the gears can be disengaged by means of a lever, allowing the drive shaft to be easily adjusted in both directions of rotation.



20160309

Fig. 7

Technical data

| | |
|--|--|
| Operating voltage | AC 220...240 V - 15% / +10% AC 100...110 V - 15% / +10% |
| Mains frequency | 50...60 Hz ± 6% |
| Switching capacity of auxiliary devices and limit switches | 10 (3) A, AC 24...250 V |
| Angle positioning | up to 160° (full scale) |
| Assembly position | option |
| Protection level | IP 54, DIN 40050 |
| Safety class | I |
| Weight | approx. 0.8 kg |
| Actuator motor | synchronous motor |
| Power absorption | 6.5 VA |
| Environmental conditions: | |
| Operation | DIN EN 60 721-3-1 |
| Climatic conditions | Class 1K2 |
| Mechanical conditions | Class 1M2 |
| Temperature range | -20...+60°C |
| Humidity | < 95% RH |

Tab. F

6 Installation

6.1 Notes on safety for the installation

After carefully cleaning all around the area where the burner is to be installed, and arranging for the environment to be illuminated correctly, proceed with the installation operations.



All the installation, maintenance and disassembly operations must be carried out with the electricity supply disconnected.



The installation of the burner must be carried out by qualified personnel, as indicated in this manual and in compliance with the standards and regulations of the laws in force.



The combustion air inside the boiler must be free from hazardous mixes (e.g.: chloride, fluoride, halogen); if present, it is highly recommended to carry out cleaning and maintenance more frequently.

6.2 Handling

The burner packaging includes a wooden platform, it is therefore possible to handle the burner (still packaged) with a pallet truck or fork lift truck.



Burner handling operations can be highly dangerous if not carried out with the greatest attention: distance unauthorised personnel, check integrity and suitability of the means available. Check also that the area in which you are working is empty and that there is an adequate escape area (i.e. a free, safe area to which you can quickly move if the burner should fall). When handling, keep the load at not more than 20-25cm from the ground.



After positioning the burner near the installation point, correctly dispose of all residual packaging, separating the various types of material.



Before proceeding with the installation operations, carefully clean all around the area where the burner will be installed.

6.3 Preliminary checks

Checking the consignment



After removing all the packaging, check the integrity of the contents. In the event of doubt, do not use the burner; contact the supplier.



The packaging elements (wooden cage or cardboard box, nails, clips, plastic bags, etc.) must not be abandoned as they are potential sources of danger and pollution; they should be collected and disposed of in the appropriate places.

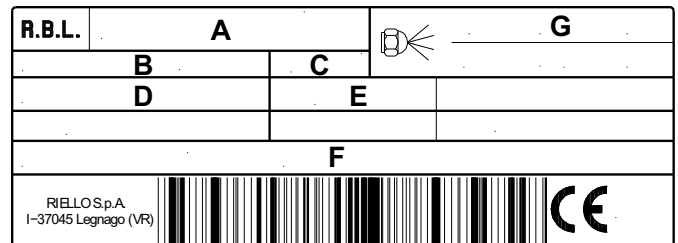

S9762

Fig. 8

Checking the characteristics of the burner

Check the identification label of the burner, showing:

- the model (A)(Fig. 8) and type of burner (B);
- the year of manufacture, in cryptographic form (C);
- the serial number (D);
- the data for electrical supply and the protection level (E);
- the absorbed electrical power (F);
- the types of gas used and the relative supply pressures (G);
- the data of the burner's minimum and maximum output possibilities (H)(see Firing rate)

Warning. The burner output must be within the boiler's firing rate.

- the category of the appliance/countries of destination (I).
- light oil maximum viscosity (L).



A burner label that has been tampered with, removed or is missing, along with anything else that prevents the definite identification of the burner makes any installation or maintenance work difficult.

6.4 Operating position



- The burner is set up to operate only in positions **1, 2, 3** and **4** (Fig. 9).
- Installation **1** is preferable, as it is the only one that allows the maintenance operations as described in this manual.
- Installations **2, 3** and **4** permit operation but make maintenance and inspection of the combustion head more difficult.



- Any other position could compromise the correct operation of the appliance.
- Installation **5** are forbidden for safety reasons.

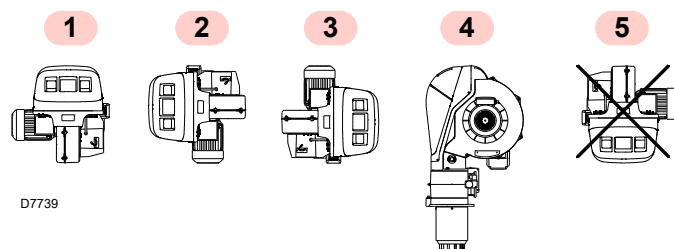

Fig. 9

6.5 Boiler plate

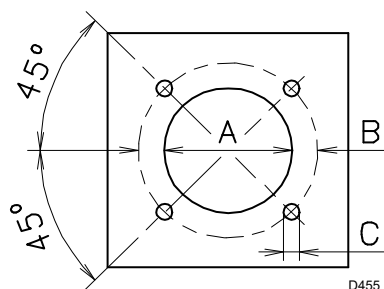

Fig. 10

Drill the combustion chamber locking plate as shown in (Fig. 10). The position of the threaded holes can be marked using the thermal screen supplied with the burner.

| mm | A | B | C |
|----------|-----|---------|------|
| RL 70/M | 185 | 275-325 | M 12 |
| RL 100/M | 185 | 275-325 | M 12 |
| RL 130/M | 195 | 275-325 | M 12 |

Tab. G

6.6 Blast tube length

The length of the blast tube must be selected according to the indications provided by the manufacturer of the boiler, and in any case it must be greater than the thickness of the boiler door complete with its fettling. The range of lengths available, L (mm), is as follows:

| Boccaglio 9) | RL 70/M | RL 100/M | RL 130/M |
|--------------|---------|----------|----------|
| Corto | 272 | 272 | 272 |
| Lungo | 385 | 385 | 385 |

Tab. H

For boilers with front flue passes 12) or flame inversion chambers, protective fettling in refractory material 10) must be inserted between the boiler fettling 11) and the blast tube 9).

This protective fettling must not compromise the extraction of the blast tube.

For boilers having a water-cooled front the refractory fettling 10)-11)(Fig. 11) is not required unless it is expressly requested by the boiler manufacturer.

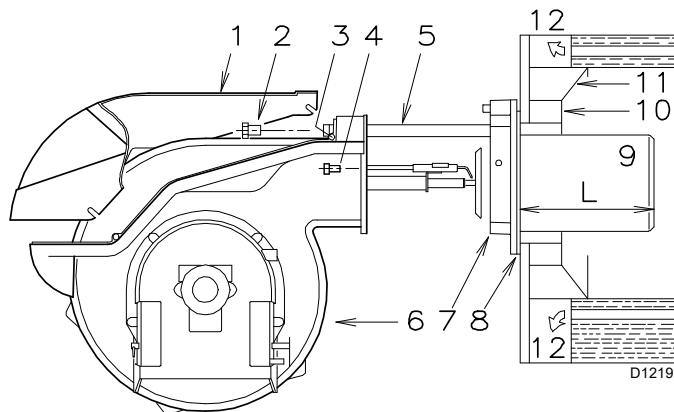

Fig. 11

6.7 Securing the burner to the boiler



Provide an adequate lifting system.



Be careful as some drops of fuel may leak out during this phase.

Disassemble the blast tube 9) from the burner 6) by proceeding as follows:

- loosen the four screws 3) and remove the cover 1);
- remove the screws 2) from the two slide bars 5);
- remove the two screws 4) fixing the burner 6) to the flange 7);
- withdraw the blast tube 9) complete with flange 7) and slide bars 5).

Once this operation has been carried out (if it was required), secure flange 7)(Fig. 11) to the boiler plate interposing the supplied gasket 8). Use the 4 screws provided after having protected the thread with anticruffing products.

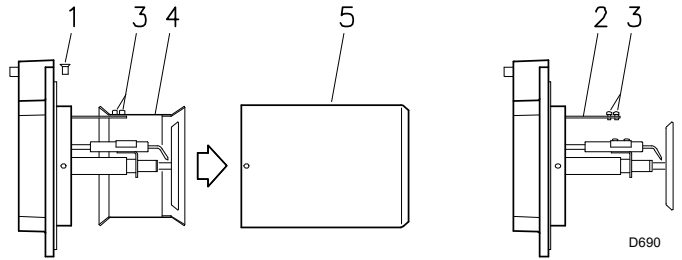

Fig. 12

6.7.1 Combustion head calibration

At this point check, for model RL 130/M, whether the maximum delivery of the burner in 2nd stage operation is contained in area B or in area C of the firing rate. See page 9.

If it is in area B then no operation is required.

If, on the other hand, it is in area C:

- unscrew the screws 1)(Fig. 12) and disassemble the blast tube 5);
- unscrew the screws 3) and remove the shutter 4);
- tighten the screws 3) on the rod 2);
- now refit the blast tube 5) and the screws 1).



The seal between burner and boiler must be airtight.

6.8 Electrode positions



WARNING

Check that the electrodes are positioned correctly, as in Fig. 13, complying with the dimensions indicated.

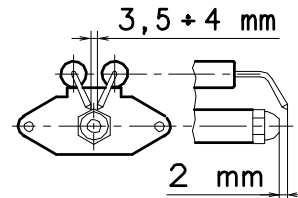

D856

Fig. 13

6.9 Nozzle installation

The burner complies with the emission requirements of the EN 267 standard. In order to guarantee that emissions do not vary, recommended and/or alternative nozzles specified by Riello in the Instruction and warning booklet should be used.



It is advisable to replace the nozzle once a year during periodical maintenance.



The use of nozzles other than those specified by Riello S.p.A. and inadequate regular maintenance may result into emission limits non-conforming to the values set forth by the regulations in force, and in extremely serious cases, into potential hazards to people and objects.

The manufacturing Company shall not be liable for any such damage arising from non-observance of the requirements contained in this manual.

6.10 Nozzle assembly

At this stage of installation the burner is still disassembled from the blast tube; it is therefore possible to fit the nozzle with the box spanner 1)(Fig. 15), fitting the spanner through the central hole in the flame stability disk. Do not use any sealing products such as gaskets, sealing compound, or tape. Be careful to avoid damaging the nozzle sealing seat.

Finally refit the burner 3)(Fig. 16) to the slide bars 2) and slide it up to the flange 5), **keeping it slightly raised to prevent the flame stability disk from pressing against the blast tube.**

Tighten the screws 1) on the slide bars 2) and screws 4) fixing the burner to the flange.

If it proves necessary to change a nozzle with the burner already fitted to the boiler, proceed as outlined below:

- Retract the burner on its slide bars as shown in (Fig. 6 on page 12).
- Remove the nuts 1)(Fig. 11 on page 15) and the disk 2).
- Use spanner 3)(Fig. 11 on page 15) to change the nozzles.



- Do not use any sealing products such as: gaskets, tape or sealants.
- Be careful to avoid damaging the nozzle sealing seat.
- The nozzle must be screwed into place tightly but not to the maximum torque value provided by the wrench.

6.9.1 Choice of nozzle

See diagram (Fig. 28 on page 24).

In case an intermediate delivery between the two values indicated in the diagram (Fig. 28 on page 24), is required, a nozzle with higher delivery must be chosen. Delivery reduction will be obtained by means of the pressure regulator.

RECOMMENDED NOZZLES:

Type A3 or A4 Bergonzo nozzles - 45° angle

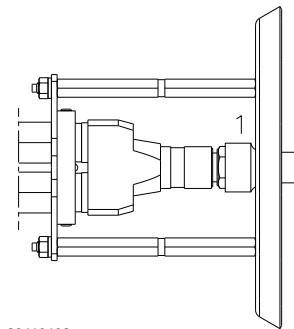

Fig. 14

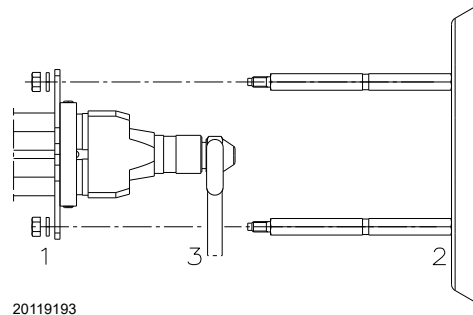

Fig. 15

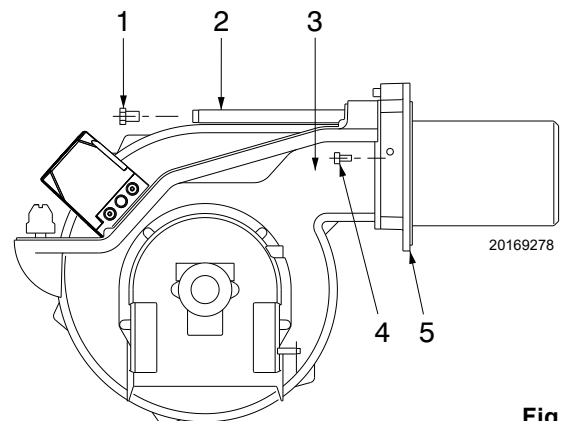

Fig. 16

6.11 Combustion head setting

The setting of the combustion head depends exclusively on the maximum burner delivery at which it will be operating.

Turn screw 4)(Fig. 17) until the notch shown in diagram (Fig. 18) is level with the front surface of flange 5)(Fig. 17).

Example:

RL 70/M, maximum light oil delivery = 50 kg/h

Diagram (Fig. 18) indicates that for a delivery of 50 kg/h the RL 70/M Model requires the combustion head to be set to approx. three notches, as shown in Fig. 17.

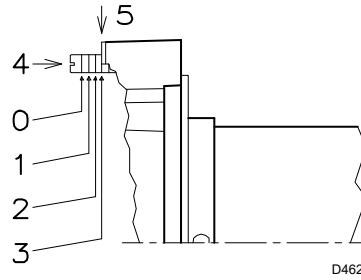

Fig. 17

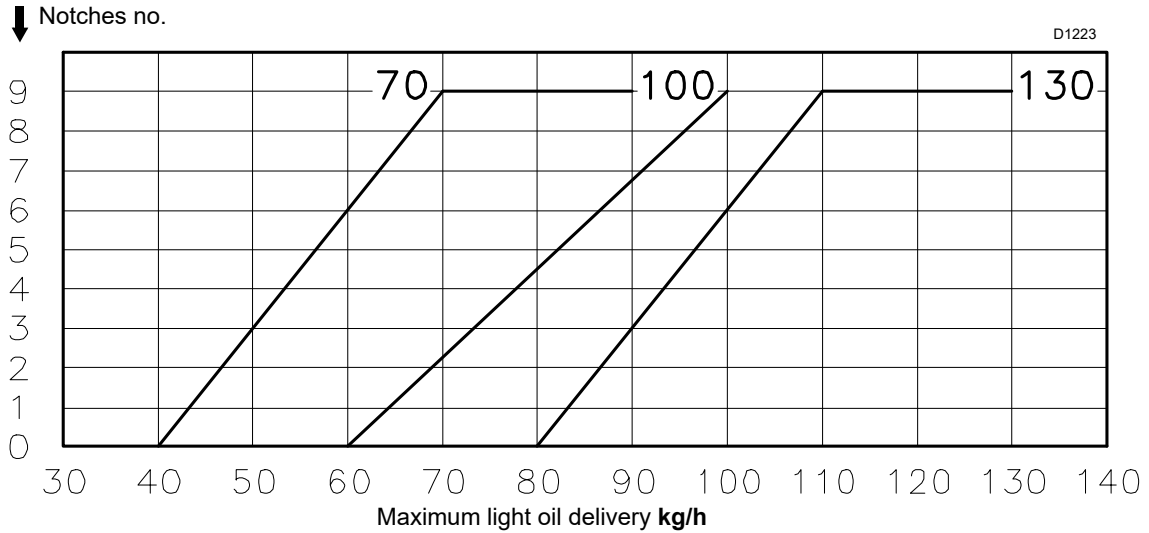

Fig. 18

6.12 Light oil supply



Explosion danger due to fuel leaks in the presence of a flammable source.

Precautions: avoid knocking, attrition, sparks and heat.

Make sure the fuel shut-off valve is closed before performing any operation on the burner.



WARNING

The fuel supply line must be installed by qualified personnel, in compliance with current standards and laws.

Double-pipe circuit

The burner is equipped with a self-priming pump which is capable of feeding itself within the limits listed in the table at the side.

The tank higher than the burner A

The distance "P" must not exceed 10 meters in order to avoid subjecting the pump's seal to excessive strain; the distance "V" must not exceed 4 meters in order to permit pump self-priming even when the tank is almost completely empty.

The tank lower than the burner B

Pump depression values higher than 0.45 bar (35 cm Hg) must not be exceeded because at higher levels gas is released from the fuel, the pump starts making noise and its working life-span decreases.

It is good practice to ensure that the return and suction lines enter the burner from the same height; in this way it will be less probable that the suction line fails to prime or stops priming.

The loop circuit

A loop circuit consists of a loop of piping departing from and returning to the tank with an auxiliary pump that circulates the fuel under pressure. A branch connection from the loop goes to feed the burner. This circuit is extremely useful whenever the burner pump does not succeed in self-priming because the tank distance and/or height difference are higher than the values listed in Tab. H.

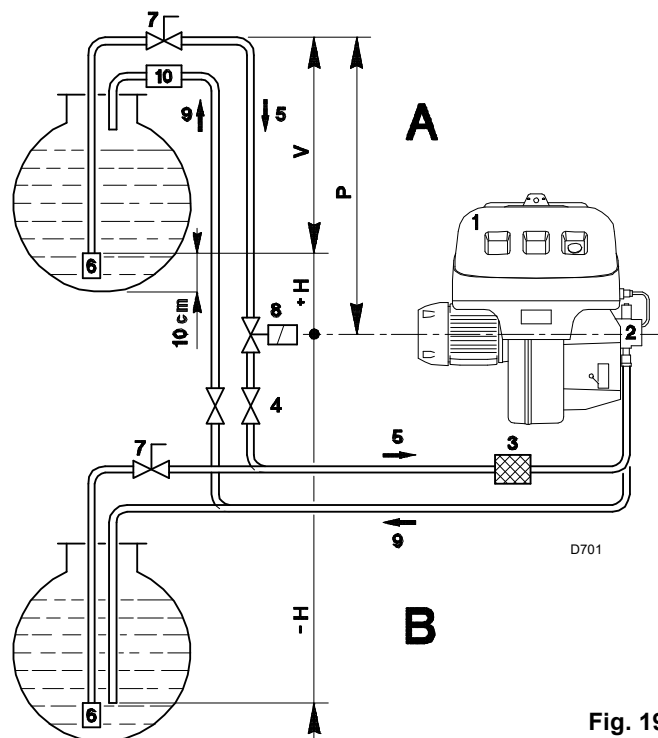

Fig. 19

| + H - H (m) | L (m) | | | | | |
|-------------------|-------------------|-----|-----|----------------------------|-----|-----|
| | RL 70/M Ø (mm) | | | RL 100/M - 130/M Ø (mm) | | |
| | 10 | 12 | 14 | 12 | 14 | 16 |
| + 4.0 | 51 | 112 | 150 | 71 | 138 | 150 |
| + 3.0 | 45 | 99 | 150 | 62 | 122 | 150 |
| + 2.0 | 39 | 86 | 150 | 53 | 106 | 150 |
| + 1.0 | 32 | 73 | 144 | 44 | 90 | 150 |
| + 0.5 | 29 | 66 | 132 | 40 | 82 | 150 |
| 0 | 26 | 60 | 120 | 36 | 74 | 137 |
| - 0.5 | 23 | 54 | 108 | 32 | 66 | 123 |
| - 1.0 | 20 | 47 | 96 | 28 | 58 | 109 |
| - 2.0 | 13 | 34 | 71 | 19 | 42 | 81 |
| - 3.0 | 7 | 21 | 46 | 10 | 26 | 53 |
| - 4.0 | - | 8 | 21 | - | 10 | 25 |

Tab. I

Key

- H = Pump/foot valve height difference
- L = Piping length
- Ø = Inside pipe diameter
- 1 = Burner
- 2 = Pump
- 3 = Filter
- 4 = Manual on/off valve
- 5 = Suction line
- 6 = Foot valve
- 7 = Rapid closing manual valve remote controlled (only Italy)
- 8 = On/off solenoid valve (only Italy)
- 9 = Return line
- 10 = Check valve (only Italy)

6.12.1 Hydraulic connections



➤ Make sure that the hoses to the pump supply and return line are installed correctly.

The pumps are equipped with a by-pass that connects return line with suction line. The pumps are installed on the burner with the by-pass closed by screw 6)(Fig. 22).

It is therefore necessary to connect both hoses to the pump.

The pump will break down immediately if it is run with the return line closed and the by-pass screw inserted.

Remove the plugs from the suction and return connections of the pump.

Insert the hose connections with the supplied seals into the connections and screw them down.

Take care that the hoses are not stretched or twisted during installation.

Install the hoses where they cannot be stepped on or come into contact with hot surfaces of the boiler.

Now connect the other end of the hoses to the suction and return lines by using the supplied nipples.



During the installation, hoses must not be stressed with twisting.

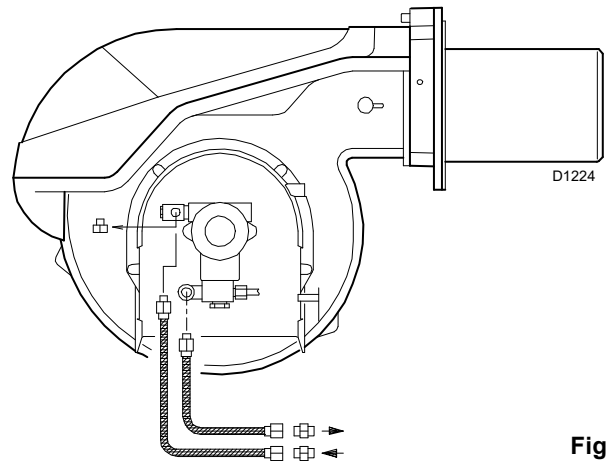

Fig. 20

6.12.2 Scheme of hydraulic circuit

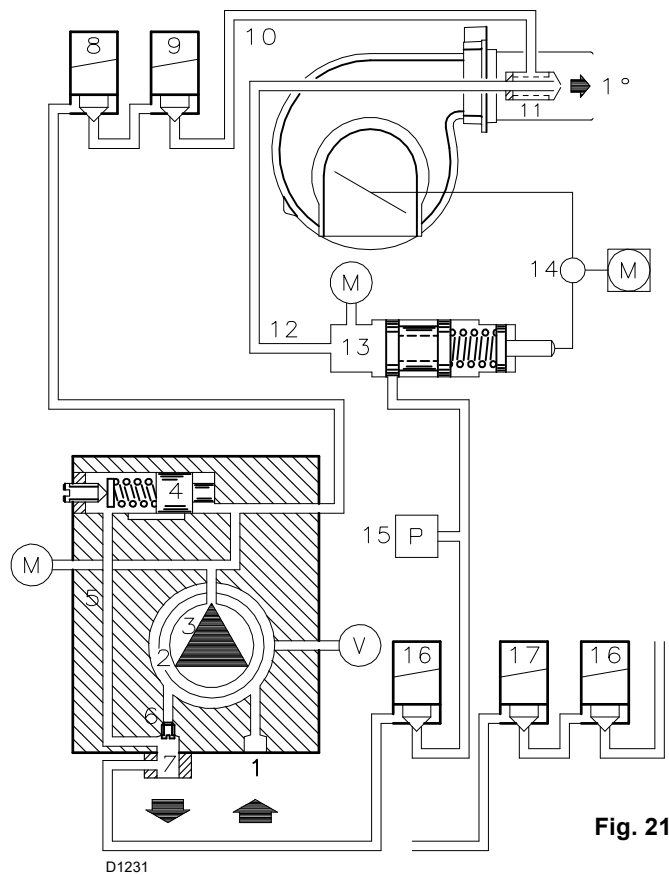

Fig. 21

- 1 Pump suction line
- 2 Filter
- 3 Pump
- 4 Pressure adjuster
- 5 Pressure test point
- 6 Bypass screw
- 7 Pump return line
- 8 Safety valve
- 9 Operation valve
- 10 Delivery pipeline
- 11 Nozzle
- 12 Return pipeline
- 13 Pressure adjuster
- 14 Eccentric for pressure adjuster
- 15 Maximum oil pressure switch
- 16 Return valve
- 17 Return valve
- M Pressure gauge
- V vacuumeter

6.13 Pump

6.13.1 Technical data

| Pompa | | J7 C |
|---------------------------------------|------|-----------|
| Min. delivery rate at 20 bar pressure | kg/h | 190 |
| Delivery pressure range | bar | 10 - 21 |
| Max. suction depression | bar | 0,45 |
| Viscosity range | cSt | 2,8 - 200 |
| Light oil max. temperature | °C | 90 |
| Max. suction and return pressure | bar | 1,5 |
| Pressure calibration in the factory | bar | 20 |
| Filter mesh width | mm | 0,170 |

Tab. J

6.13.2 Pump priming

- Before starting the burner, make sure that the tank return line is not clogged. Obstructions in the line could cause the sealing organ located on the pump shaft to break.
- In order for self-priming to take place, one of the screw 3)(Fig. 22) of the pump must be loosened in order to bleed off the air contained in the suction line.
- Start the burner by closing the control devices with switch 1)(Fig. 27) in the "MAN" position. As soon as the burner starts, check the direction of rotation of the fan blade, by looking through the flame inspection window 25)(Fig. 4 on page 10).
- The pump can be considered primed when the light oil starts coming out of the screw 3). Stop the burner: switch 1)(Fig. 27 on page 24) set to "OFF" and tighten the screw 3).

The time required for this operation depends upon the diameter and length of the suction tubing. If the pump fails to prime at the first starting of the burner and the burner locks out, wait approx. 15 seconds, reset the burner, as often as required. After 5 or 6 starting operations allow 2 or 3 minutes for the transformer to cool.



WARNING

The a.m. operation is possible because the pump is already full of fuel when it leaves the factory. If the pump has been drained, fill it with fuel through the opening on the vacuum meter prior to starting; otherwise, the pump will seize.

Whenever the length of the suction piping exceeds 20-30 meters, the supply line must be filled using a separate pump.

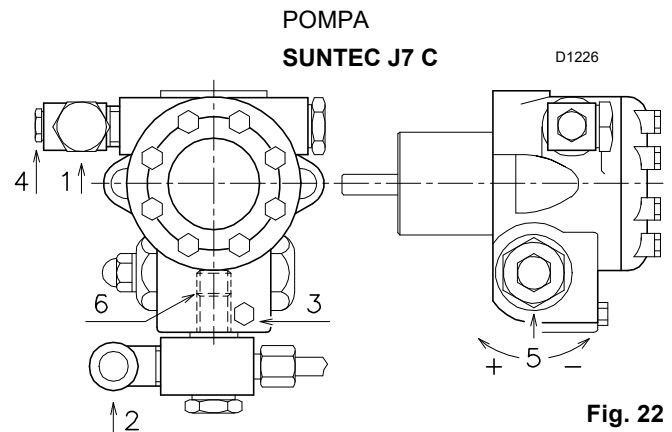

- | | | |
|---|---------------------------|--------|
| 1 | Suction | G 1/2" |
| 2 | Return | G 1/2" |
| 3 | Pressure gauge connection | G 1/8" |
| 4 | Vacuum meter connection | G 1/8" |
| 5 | Pressure adjustment screw | |
| 6 | Screw for by-pass | |

6.14 Electrical connections

Notes on safety for the electrical wiring



- The electrical wiring must be carried out with the electrical supply disconnected.
- Electrical wiring must be made in accordance with the regulations currently in force in the country of destination and by qualified personnel. Refer to the wiring diagrams.
- The manufacturer declines all responsibility for modifications or connections different from those shown in the wiring diagrams.
- Check that the electrical supply of the burner corresponds to that shown on the identification label and in this manual.
- The burners have been set for intermittent operation (FS1).
- The RFGO safety device features two built-in flame amplifiers which allow using it for applications with UV sensor only, FR sensor only or with both sensors (UV+FR).
The FR amplifier circuit is subject to constant auto-control, which allows to use it for applications requiring a burner operating cycle longer than 24 hours.
When it is used as a UV control, the system is considered as non-permanent, requiring one burner recycle every 24 hours.
Normally, burner stopping is guaranteed by the boiler's thermostat/pressure switch.
If this is not the case, a time switch must be applied to L-N in series, to stop the burner at least once every 24 hours. Refer to the wiring diagrams.
- The electrical safety of the device is obtained only when it is correctly connected to an efficient earthing system, made according to current standards.
It is necessary to check this fundamental safety requirement. In the event of doubt, have the electrical system checked by qualified personnel.
Do not use the gas tubes as an earthing system for electrical devices.
- The electrical system must be suitable for the maximum power absorption of the device, as indicated on the label and in the manual, checking in particular that the section of the cables is suitable for that level of power absorption.
- For the main power supply of the device from the electricity mains:
 - do not use adapters, multiple sockets or extensions;
 - make provisions for an omnipolar switch with a gap between the contacts of at least 3 mm (over-voltage category III), as required by current safety regulations.
- Do not touch the device with wet or damp body parts and/or in bare feet.
- Do not pull the electric cables.

Before carrying out any maintenance, cleaning or checking operations:



Disconnect the electrical supply from the burner by means of the main system switch.



Close the fuel shut-off valve.



Avoid condensate, ice and water leaks from forming.

If the cover is still present, remove it and proceed with the electrical wiring according to the wiring diagrams.

Use flexible cables according to standard EN 60 335-1.

6.14.1 Supply cables and external connections passage

All the cables to be connected to the burner terminal board 8)(Fig. 23 and Fig. 24) must be threaded through cable grommets.

The use of the cable grommets and the pre-blanked holes can be done in different manners; for example:

Key (Fig. 23 and Fig. 24)

RL 70/M (Fig. 23)

- 1 Pg 13,5 Three-phase power supply
- 2 Pg 11 Single-phase power supply
- 3 Pg 13.5 Control device TL
- 4 Pg 9 Control device TR or probe (RWF)
- 5 Pg 9 Set up for fair lead
- 6 Pg 11 Set up for fair lead
- 7 Pg 13,5 Set up for fair lead

RL 100/M - RL 130/M (Fig. 24)

- 1 Pg 13,5 Three-phase power supply
- 2 Pg 11 Single-phase power supply
- 3 Pg 13.5 Control device TL
- 4 Pg 13,5 Control device TR or probe (RWF)
- 5 Pg 9 Set up for fair lead
- 6 Pg 11 Set up for fair lead

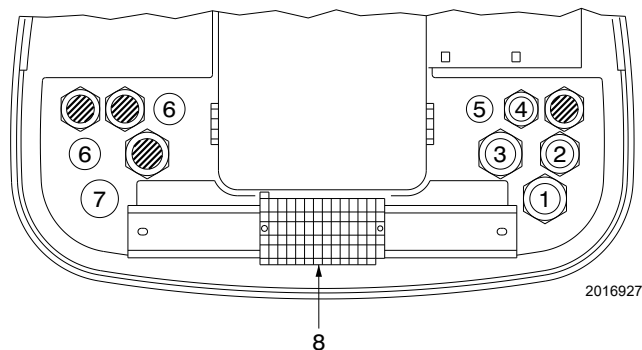

RL 70/M

Fig. 23

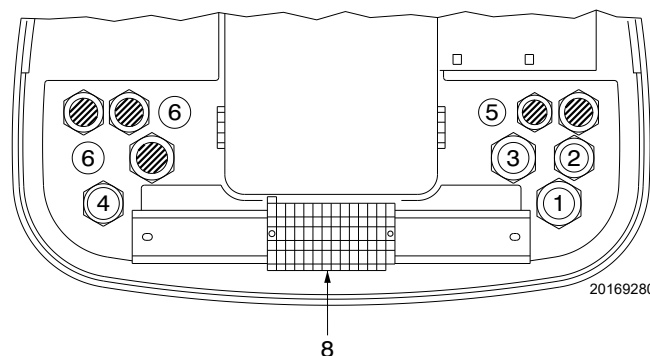

RL 100/M - RL 130/M

Fig. 24



After carrying out maintenance, cleaning or checking operations, reassemble the cover and all the safety and protection devices of the burner.

6.15 Calibration of the thermal relay

The thermal relay serves to avoid damage to the motor due to an excessive absorption increase or if a phase is missing.

For calibration 2), refer to the table indicated in the electrical layout (electrical wiring in charge of the installer).

To reset, in case of an intervention of the thermal relay, press button "RESET" 1).

The button "STOP" 3) opens the NC contact (95-96) and stops the motor.

Insert a screwdriver in the window "TEST/TRIP" 4) and move it in the arrow direction (to the right) to carry out the thermal relay test.

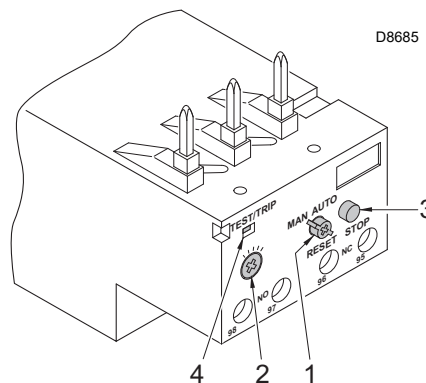

Fig. 25



The automatic reset can be dangerous. This operation is not foreseen in the burner operation.

6.16 Motor rotation

As soon as the burner starts, place yourself in front of the cooling fan of the fan motor and check that it turns anticlockwise (Fig. 26).

If this is not the case:

- put the switch of the burner to "0" (off) and wait until the control box carries out the switching off phase.



Disconnect the electrical supply from the burner by means of the system main switch.

- Invert the phases on the three-phase motor power supply.

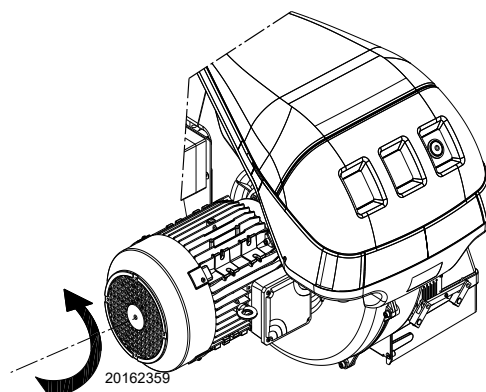

Fig. 26

7 Start-up, calibration and operation of the burner

7.1 Notes on safety for the first start-up



The first start-up of the burner must be carried out by qualified personnel, as indicated in this manual and in compliance with the standards and regulations of the laws in force.



Check the correct working of the adjustment, command and safety devices.

7.2 Burner firing

Close load controls and set switch 1)(Fig. 27) to "MAN". After burner firing a complete burner adjustment should be performed.

Notes on safety for the first start-up



The first start-up of the burner must be carried out by qualified personnel, as indicated in this manual and in compliance with the standards and regulations of the laws in force.



Check the correct working of the adjustment, command and safety devices.

Set switch 1)(Fig. 27) to "ON".

During the first firing, during the passage from the 1st to the 2nd stage, there is a momentary lowering of the fuel pressure caused

by the filling of the 2nd stage nozzle tubing. This lowering of the fuel pressure can cause the burner to lock-out and can sometimes give rise to pulsations.

Once the following adjustments have been made, the firing of the burner must generate a noise similar to the noise generated during operation. If one or more pulsations or a delay in firing in respect to the opening of the light oil solenoid valve occur, see the suggestions provided on page 34.

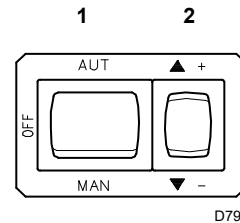

Fig. 27

7.3 Operation

The optimum calibration of the burner requires an analysis of the flue gases at the boiler outlet.

The following settings that have already been made do not require modification under normal circumstances:

- Combustion head
- Servomotor, cams I - II - IV - V

Contrarily, the settings listed below must be adjusted in sequence:

- 1 MAX burner output;
- 2 MIN burner output;
- 3 Intermediate outputs between MAX and MIN output.

1 - MAX output

Max output of the burner must be set within the firing rate range shown on page 9.

In the above instructions we left the burner running in MIN output operation. Now press button 2)(Fig. 27) "+" until servomotor arrives at 130°.

Adjusting the nozzle flow rate

The nozzle flow rate varies according to the fuel pressure on the nozzle return.

Diagram (Fig. 28) indicates this relationship for type A3 and A4 Bergonzo nozzles with pump delivery pressure of 20 bars.

Diagram:

- Horizontal axis : bar, nozzle return pressure
- Vertical axis : kg/h, nozzle flow rate

NOTE:

with a pump delivery pressure of 20 bar, the pressure on the nozzle return must not exceed 17 bars.

The pressure difference between pump delivery and nozzle return must be at least 3 bars. With smaller pressure differences, the pressure on the nozzle return can be unstable.

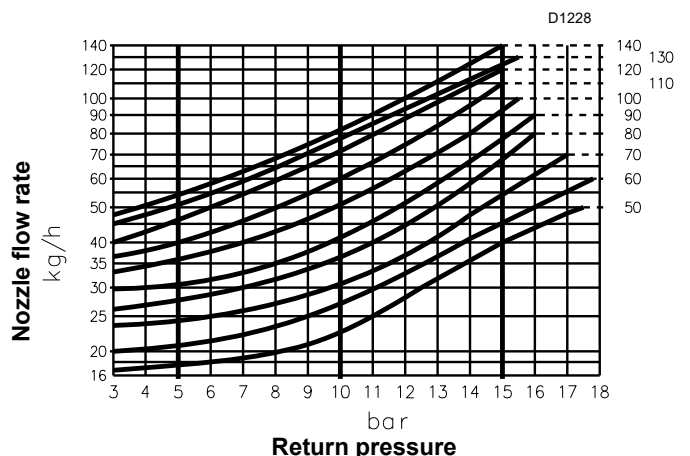

Fig. 28

7.3.1 Pressure regulator

The nozzle return pressure value is indicated by the pressure gauge 1)(Fig. 29).

The output and the pressure of the nozzle are at maximum when the servomotor is positioned on 130°.

The fine adjustment of the pressure in the return line may be carried out by changing the setting of the eccentric 6)(Fig. 29), of the nut and lock-nut 4)(Fig. 29).

The eccentric setting should be carried out by loosening screws 7), and turning the screw 5) to obtain the desired eccentricity. Turn clockwise the screw 5) to increase the eccentricity, increasing the difference between the min. and max. capacity of the nozzle; turn counter-clockwise the screw 5) to decrease the eccentricity and, consequently the difference between the min. and max. capacity of the nozzle.

NOTE:

- **The proper setting of the eccentric 6) is possible when its operation field follows the servomotor operation field (20° ÷ 130°): so, that every variation of the servomotor position corresponds to a pressure variation.**
- **Do not let the piston beat repeatedly: the stop ring 3)(Fig. 29) determines the maximum stroke.**
- **When the setting is carried out, verify manually that no slow-down occurs between (page 26) 0° and 130° and that the maximum and minimum pressures correspond to those chosen as per diagram (Fig. 28 on page 24).**
- **If you wish to check the delivery capacity of the nozzle, open the burner, attach the nozzle, simulate the start-up and then proceed with weighing of the maximum and minimum pressures of the fuel.**
- **If at the maximum capacity of the nozzle (maximum pressure in the return line) pressure fluctuations are detected on the manometer 1), slightly decrease the pressure in the return line until they are completely eliminated.**

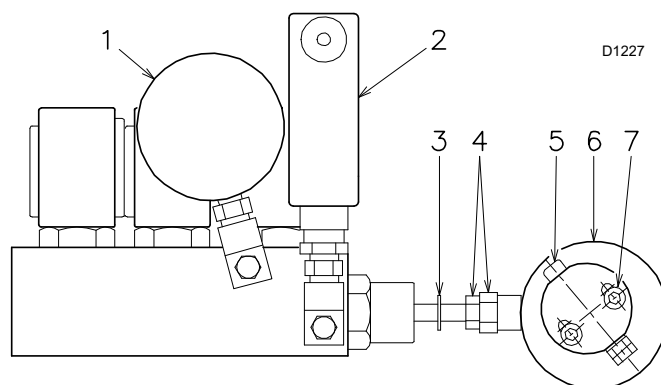

D1227

Fig. 29

- 1 Pressure gauge for pressure on nozzle return
- 2 Oil pressure switch
- 3 Ring for piston stop
- 4 Nut and lock-nut for piston setting
- 5 Eccentric adjusting screw
- 6 Variable eccentric
- 7 Eccentric locking screws

7.3.2 Adjusting air deliver

Progressively adjust the end profile of cam 2)(Fig. 30) using adjustment screws 5).

- Turn the screws clockwise to increase air delivery.
- Turn the screws counter-clockwise to reduce air delivery.

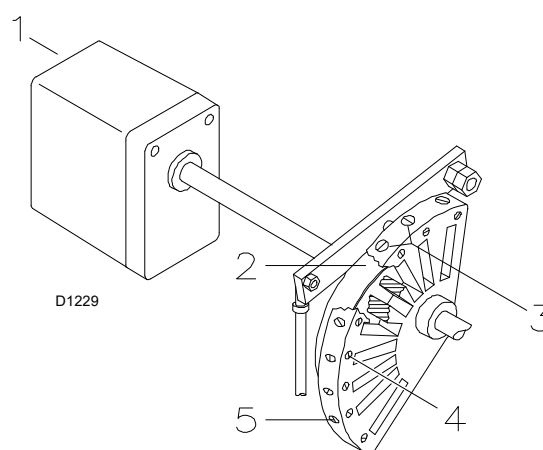

D1229

Fig. 30

- 1 Servomotor
- 2 Adjustable profile cam
- 3 Adjustment screws for cam profile
- 4 Adjustment fixing screws
- 5 Adjustment screws for cam profile

2 - Min output

Max output of the burner must be set within the firing rate range shown on page 9.

Press button 2)(Fig. 27 on page 24) “output reduction“ and keep it pressed until the servomotor has reached 20° (factory setting).

Adjusting the nozzle flow rate

The nozzle flow rate is given in diagram (Fig. 28 on page 24) corresponding to the pressure on the nozzle return read on the pressure gauge 1)(Fig. 29 on page 25).

The output and the pressure of the nozzle are at minimum when the servomotor is positioned on 20°.

To set return pressure, see page 9.

Adjusting air delivery

Progressively adjust the starting profile of cam 2)(Fig. 30) by turning the screws 3).

It is preferable not to turn the first screw since this is used to set the air gate valve to its fully closed position.

3 - Intermediate output air/oil flow rate adjustment

Press the switch 2)(Fig. 27 on page 24) “output increase“ a little so that the servomotor turns by about 15°. Adjust the screws until optimal combustion is obtained. Proceed in the same way with the other screws.

Take care that the cam profile variation is progressive.

Switch the burner off with switch 1)(Fig. 27 on page 24), at the OFF position, disengage the cam 2)(Fig. 30) from the servomotor, by pressing the button 3)(Fig. 31) and moving it to the right, and check more than once that the movement is soft and smooth, and does not grip, by rotating the cam 2) forward and backward by hand.

Engage cam 2) to the servomotor again by moving button 2)(Fig. 31) to the left.

As far as possible, try not to move those screws at the ends of the cam that were previously adjusted for the opening of the air gate to MAX and MIN output.

Once you have finished adjusting outputs MAX - MIN - INTERMEDIATE, check ignition once again: noise emission at this stage must be identical to the following stage of operation. If you notice any sign of pulsations, reduce the ignition stage delivery.

Finally fix the adjustment by turning screws 4)(Fig. 30).

NOTE:

The servomotor follows the adjustment of cam III only when the cam angle is reduced. If it is necessary to increase the cam angle, first increase the servomotor angle with the key “output increase”, then increase the III cam angle, and finally bring the servomotor back to the MIN output position with the key “output decrease”.

In order to adjust cam III, especially for fine movements, key 10)(Fig. 31), held by a magnet under the servomotor, can be used.

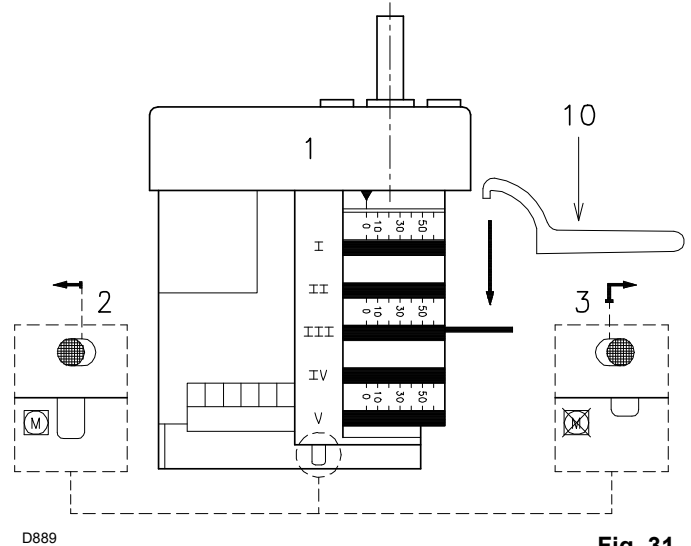

Fig. 31

7.3.3 Servomotor

The servomotor provides simultaneous adjustment of the air gate valve, by means of the variable profile cam and the pressure regulator. The servomotor rotates through 130° in 42 seconds.

Do not alter the factory setting for the 5 cams; simply check that they are set as indicated below:

- Cam I:** **130°** Limits rotation toward maximum position.
- Cam II:** **0°** Limits rotation toward the minimum position. When the burner is shut down the air gate valve must be closed: 0°.
- Cam III:** **20°** Adjusts the ignition position and the MIN output.
- Cams IV - V:** **not utilized.**

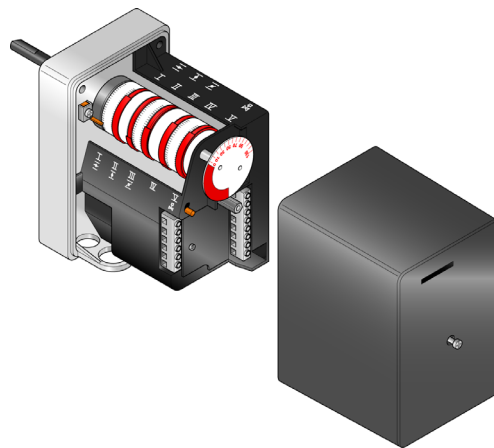

Fig. 32

7.4 Pressure switch adjustment

7.4.1 Oil pressure switch

The oil pressure switch 5)(Fig. 4 on page 10) is factory set to 3 bar. If the gas oil pressure reaches this value in the return piping, the pressure switch stops the burner.

Burner starts again automatically if the pressure goes down under 3 bar after burner shut down.

If a loop circuit with P_x pressure feeds the burner, the pressure switch should be adjusted to $P_x + 3$ bar.

To adjust the pressure switches, set the adjustment screw with a tool, see Fig. 33.

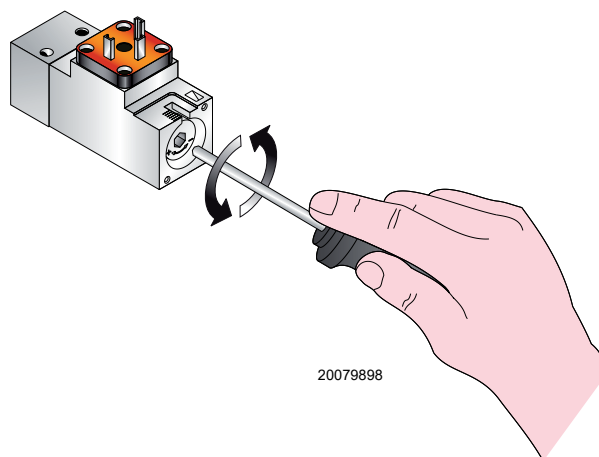

Fig. 33

7.5 Operation sequence of the burner

7.5.1 Burner starting

- 0 s :** Control device TL closes, the motor starts.
The pump 3) sucks the fuel from the tank through the piping 1) and the filter 2) and pumps it under pressure to delivery. The piston 4) rises and the fuel returns to the tank through the piping 5) - 7). The screw 6) closes the by-pass heading towards suction and the de-energized solenoid valves 8) - 9) - 16) - 17) close the passage to the nozzle.
- 6 s :** Servomotor starts: 130° rotation to right, until contact is made on cam I)(Fig. 31 on page 26).The air gate valve is positioned on MAX. output.
- 48 s :** Pre-purge stage with air delivery at MAX. output.
- 85 s :** Servomotor rotates to left until contact is made on cam III) (Fig. 31 on page 26).
- 121 s :** Air gate valve and pressure regulator are positioned on MIN output.
- 123 s :** Ignition electrode strikes a spark.
- 128 s :** Solenoid valves 8) - 9) - 16) open; the fuel passes through the piping 10) and filter 11), and enters the nozzle.
A part of the fuel is then sprayed out through the nozzle, igniting when it comes into contact with the spark: flame at a low output level, point A; the rest of the fuel passes through piping 12 at the pressure adjusted by the regulator 13, then, through piping 7), it goes back into the tank.
- 131 s :** The spark goes out.
- 153 s :** The starting cycle ends.

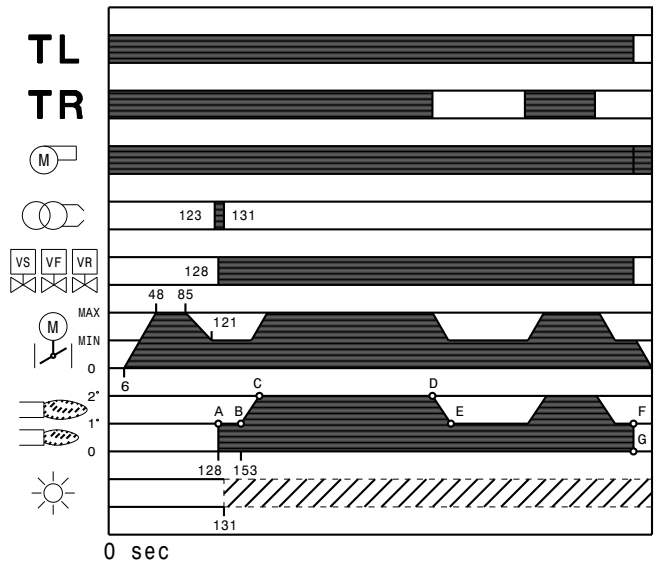

Fig. 34

7.5.2 Steady state operation (Fig. 34)

Burner without output regulator RWF

At the end of the starting cycle, the servo-motor control then passes to load control TR for boiler pressure or temperature, point B.

- If the temperature or pressure is low (and the TR load control is consequently closed), the burner progressively increases output up to MAX (section B-C).
- If subsequently the temperature or pressure increases until TR opens, the burner progressively decreases output down to MIN (section D-E). And so on.
- The burner locks out when demand for heat is less than the heat supplied by the burner in the MIN output (section F-G). Load control TL opens. The servomotor returns to the 0° angle limited by contact with cam II)(Fig. 31 on page 26). The gate valve closes completely to reduce thermal dispersion to a minimum.

Every time output is changed, the servomotor automatically modifies gas oil delivery (pressure regulator) and air delivery (fan gate valve).

Burner with output regulator RWF

See the handbook enclosed with the regulator.

7.5.3 Firing failure

If the burner does not fire, it goes into lock-out within 2.5 s of the opening of the light oil valve and the pre-purging phase starts and lasts 15 seconds.

7.5.4 Undesired shut-down during operation

If the flame should go out for accidental reasons during operation, the burner will lock out in 1 s.

7.6 Final checks

- **Obscure the flame sensor and switch off the control devices:** the burner should start and then lock-out about 5 s after starting.
- **Illuminate the flame sensor and switch off the control devices:** burner should go into lock-out.
- **Obscure the flame sensor while the burner is operating:** flame should go out and burner lock out within 1 s.
- **Switch off control device TL followed by control device TS while the burner is operating:** the burner should stop.



Make sure that the mechanical locking systems on the various adjustment devices are fully tightened.

8 Maintenance

8.1 Notes on safety for the maintenance

The periodic maintenance is essential for the good operation, safety, yield and duration of the burner.

It allows you to reduce consumption and polluting emissions and to keep the product in a reliable state over time.



The maintenance interventions and the calibration of the burner must only be carried out by qualified, authorised personnel, in accordance with the contents of this manual and in compliance with the standards and regulations of current laws.

Before carrying out any maintenance, cleaning or checking operations:



Disconnect the electrical supply from the burner by means of the main system switch.



Close the fuel shut-off valve.



Wait for the components in contact with heat sources to cool down completely.

8.2 Maintenance programme

8.2.1 Maintenance frequency



The gas combustion system should be checked at least once a year by a representative of the manufacturer or another specialised technician.

8.2.2 Checking and cleaning



The operator must use the required equipment during maintenance.

Combustion

It is required an analysis of the flue gases at the boiler outlet. Significant differences with respect to the previous measurements indicate the points where more care should be exercised during maintenance.

If the combustion values measured before starting maintenance do not comply with applicable Standards or do not indicate efficient combustion, consult the table below or contact our Technical Support Service to implement the necessary adjustments.

| EN 267 | Air excess | | CO |
|---|-----------------------------------|-----------------------------------|--------|
| | Max. output $\lambda \leq 1.2$ | Min. output $\lambda \leq 1.3$ | |
| Theoretical max CO ₂ 0 % O ₂ | CO ₂ % Calibration | | mg/kWh |
| | $\lambda = 1.2$ | $\lambda = 1.3$ | |
| 15.2 | 12.6 | 11.5 | ≤ 100 |

Tab. K

Pump

The pump delivery pressure must be stable at 20 bar.

The depression must be less than 0.45 bar.

Unusual noise must not be evident during pump operation.

If the pressure is found to be unstable or if the pump runs noisily, the flexible hose must be detached from the line filter and the fuel must be sucked from a tank located near the burner. This measure permits the cause of the anomaly to be traced to either the suction line or the pump.

If the pump is found to be responsible, check to make sure that the filter is not dirty. The vacuum meter is installed up-line from the filter and consequently will not indicate whether the filter is clogged or not.

Contrarily, if the problem lies in the suction line, check to make sure that the filter is clean and that air is not entering the piping.

Servomotor

Disengage the cam 2)(Fig. 31 on page 26) from the servomotor, by pressing and moving button 3)(Fig. 31 on page 26) towards the right, and turn it backwards and forwards by hand to make sure it moves freely. Now engage the cam again by moving the button 2)(Fig. 31 on page 26) to the left.

Filters (Fig. 35)

Check the following filter boxes:

- on line 1)
- in pump 2)
- at nozzle 3), and clean or replace as required.

If rust or other impurities are observed inside the pump, use a separate pump to suck out any water and other impurities that may have deposited on the bottom of the tank.

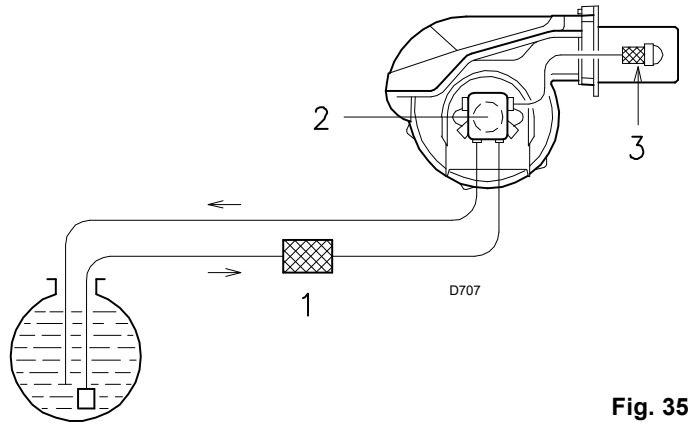

Fig. 35

Combustion head

Check to make sure that all the parts of the combustion head are in good condition, positioned correctly, free of all impurities, and that no deformation has been caused by operation at high temperatures.

Nozzle

It is advisable to replace nozzles once a year during periodical maintenance.

Do not clean the nozzle openings.

Flame sensor

Clean the glass cover from any dust that may have accumulated. The sensor 1) can be removed by pulling it outward forcefully.

Flame inspection window

Clean the glass.

Flexible hoses

Check to make sure that the flexible hoses are still in good condition.

Fuel tank

Every 5 years, or whenever necessary, suck out any water or other impurities present on the bottom of the tank using a separate pump.

Burner

Make sure that the screws are fully tightened.

Flame presence check

Check the level of the flame detection signal with the “Check mode” function from the flame control: the LEDs from 2 to 6 indicate the flame signal level, respectively. See “LED indicator and special function” on page 32..

Check Mode

With burner flame on:

- hold the reset button on the flame control pressed for at least 3 sec.;
- the button colour will change from green to yellow;
- each operating status signalling LED will be compared to 20% of the maximum brightness;
- press the reset button again (<0.5sec) to reset the standard operation of the signalling LEDs.

Clean the boiler as indicated in its accompanying instructions in order to maintain all the original combustion characteristics intact, especially the flue gas temperature and combustion chamber pressure.

Fuel pump and/or couplings replacement

Carry out in conformity with (Fig. 38).

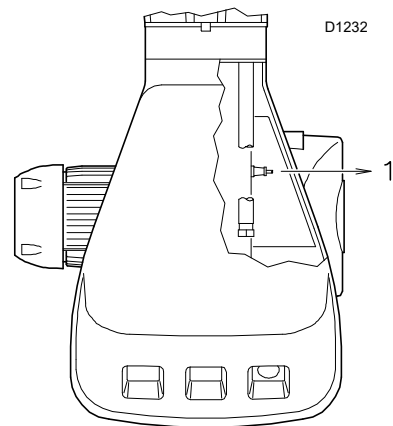

Fig. 36

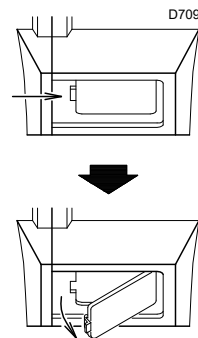

Fig. 37

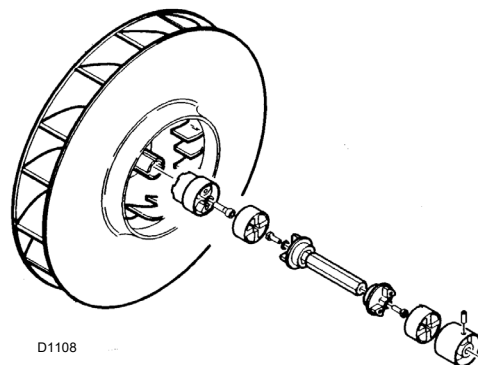

Fig. 38

8.2.3 Safety components

The safety components should be replaced at the end of their life cycle indicated in the following table.

The specified life cycles do not refer to the warranty terms indicated in the delivery or payment conditions.

| Safety component | Life cycle |
|--------------------------------|--------------------------------------|
| Flame control | 10 years or 250,000 operation cycles |
| Flame sensor | 10 years or 250,000 operation cycles |
| Gas valves (solenoid) | 10 years or 250,000 operation cycles |
| Pressure switches | 10 years or 250,000 operation cycles |
| Pressure adjuster | 15 years |
| Servomotor (electronic cam) | 10 years or 250,000 operation cycles |
| Oil valve (solenoid) | 10 years or 250,000 operation cycles |
| Oil regulator | 10 years or 250,000 operation cycles |
| Pipes/ oil fittings (metallic) | 10 years |
| Flexible hoses (if present) | 5 years or 30,000 pressurised cycles |
| Fan impeller | 10 years or 500,000 start-ups |

Tab. L

8.3 Opening the burner



Disconnect the electrical supply from the burner by means of the main system switch.



Close the fuel shut-off valve.



Wait for the components in contact with heat sources to cool down completely.

To open the burner, proceed as follows:

- Switch off the electrical power;
- loosen screws 1) and withdraw the cover 2);
- unscrew screws 3);
- fit the two extensions 4) supplied with the burner onto the slide bars 5) (models with 385 mm blast tube);
- pull part A backward keeping it slightly raised to avoid damaging the disk 6) on blast tube 7).

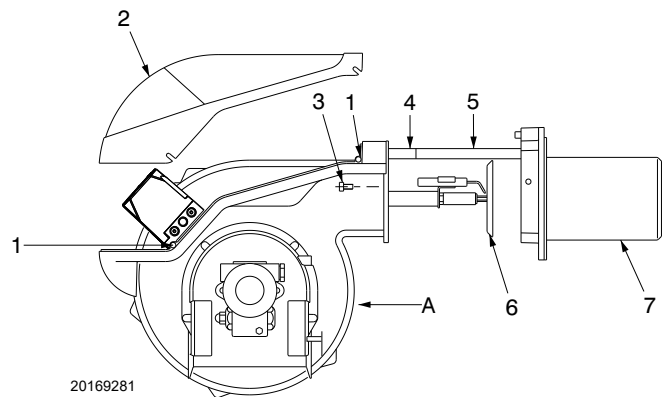

Fig. 39

8.4 Closing the burner





Refit following the steps described but in reverse order; refit all burner components as they were originally assembled.

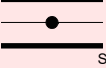
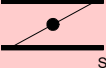

After carrying out maintenance, cleaning or checking operations, reassemble the cover and all the safety and protection devices of the burner.

9 LED indicator and special function

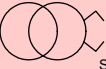
9.1 Description of LED lamps

| | | |
|---|---------------|---|
|  S9740 | Fan | It turns on when the fan motor is powered (T6) and blinks when RUN/CHECK switch is set to "CHECK" during damper movement phases, PTFI AND MTFI. |
|  S9741 | Damper open | It blinks when the air damper is moving towards the maximum opening position until the position-reached feedback sent by the servomotor is received, then it stays steadily on for the time set by the flame control. |
|  S9742 | Damper closed | If blinks when the air damper is moving towards the minimum opening position until the position-reached feedback sent by the servomotor is received, then it stays steadily on until the end of the pre-purging time. |
|  S9743 | Auto | It indicates that the burner is ready for the output modulation. |
|  S9744 | Ignition | It blinks during the ignition phase (1st safety time) and stays steadily on during the MTFI. |
|  | Flame | It blinks during the first safety time and stays steadily on if the flame detection has been correctly performed. |
|  S9746 | Alarm | It turns on in red when a lock-out condition occurs. Together with the other indicators, it indicates the type of fault during the lock-out phase. Together with the other LEDs, it indicates the operating status during the normal cycle. |

Tab. M

9.2 Check mode function

By means of the reset button on-board the flame control, it is possible to use a control function during start-up phases. (pre-purging, ignition, 1st safety time and 2nd safety time).

This function, indicated as CHECK MODE, is designed to facilitate checking the phases of the burner and of the safety devices monitored by the flame control.

This function is particularly useful during the burner first commissioning or during maintenance.

To enable the check mode function:

- keep the reset button pressed, see chapter 8 for more details, for at least 3 seconds, the status LED changes from green to yellow to signal that the control device is in check mode.
- the control device locks out during pre-purging, after a timeout of max 30 minutes the flame control will automatically exit the check mode function.





- check mode has a 2 minute timeout during the 2nd safety time. When it ends, the flame control goes back to the normal operating status.
- check mode has a 2 minute timeout during the MTFI status. When it ends, the flame control goes back to the normal operating status.
- During the check mode 1st or 2nd safety time, the flame signal level can be indicated by the 5 central LEDs on the flame control central panel, which turn on proportionally. Each lit LED (starting from the flame LED) represents 20% of the signal power.
To exit the check mode function, press the reset button; the flame control will go back to the normal operating mode.

9.3 Flame control lock-out or emergency stop condition

The RFGO control device can be locked out (emergency stop) at any time during the operating cycle and unlocked when already locked (lock-out) by simply pressing the key on the front panel or by means of the terminal T21 on the support base.

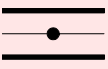
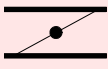
9.4 LED lamps: burner operating status

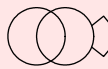
OPERATING STATUSES INDICATED BY LEDS DURING NORMAL OPERATION AND CHECK MODE

| Operation LED ● = ON | Fan | Damper open | Damper closed | Modulation | Ignition | Flame | Status |
|---|--|--|--|---|--|--|--|
| Icon |  S9740 |  S9741 |  S9742 |  S9743 |  S9744 |  S9745 |  S9746 |
| Power OFF/ON | | | | | | | OFF |
| Not ready/ Diagnostics | | | | | | | Green |
| Standby | | | ● | | | | Green |
| Servomotor movement (Note 3) | ● | OFF Flashing ● | ● Flashing OFF | | | | Green |
| Waiting for closing | Green blinking | | | | | | Green |
| OPEN (before ignition) | ● | ● | | | | | Green |
| Minimum (before ignition) | ● | | ● | | | | Green |
| Ignition | ● | | ● | | ● | | Green |
| PTFI | ● | | ● | | ● | Green blinking | Green |
| MTFI | ● | | ● | | | ● | Green |
| Active modulation | ● | | | ● | | ● | Green |
| Minimum output position | ● | | ● | | | ● | Green |
| With flame present | ● | ● | | | | ● | Green |
| Economy mode | ● | | ● | | | | Green |
| Check during maximum opening phase | Flashing | ● | | | | | Yellow |
| Check during minimum closing phase | Flashing | | ● | | | | Yellow |
| Check during ignition phase with pilot PTFI | Flashing | ● Note 1 | ● Note 1 | ● Note 1 | ● Note 1 | ● Note 1 | Yellow |
| Check during ignition phase with main fuel valve MTFI | Flashing | ● Note 1 | ● Note 1 | ● Note 1 | ● Note 1 | ● Note 1 | Yellow |
| Fault/lock-out | ● Note 2 | ● Note 2 | ● Note 2 | ● Note 2 | ● Note 2 | ● Note 2 | Red |
| End of the cycle | ● | | ● | ● | | | Green |

Tab. N

- LEDs form a progress bar which indicates the Flame Signal Power in order to orientate the sensors during commissioning (LEDs "Grow" upwards, moving away from the Status at 20% intervals of flame power.)
- LEDs indicate the error or lock-out code for troubleshooting.
- LEDs change from ON to BLINKING to OFF showing the servomotor movement control until the position-reached feedback is received see paragraph "**Problems - Causes - Remedies signalled by LED indicators**" on page 34".

10 Problems - Causes - Remedies signalled by LED indicators

When an emergency stop occurs, the control device LEDs indicate the cause of the stop.
 The terminal T3 is not powered.
 The device operating status is internally memorised in case of any lack of power supply.

The device lock-out condition can be caused by pressing (<1sec.) the reset button on the flame control front side or through the remote reset - terminal T21 on the base.
 Since the reset button is very sensitive, do not press it strongly during the reset operation.

Unlocking the control device

The RFGO control device can be reset in two ways: reset button and remote reset terminal.

The remote reset must be a normally open connected button between T21 and flame control power supply voltage (see illustrative diagrams):

- the reset is performed when a faulty condition is detected by the flame control.
- Press the reset button to reset the system after a lock-out.
- Pressing the reset button during operation will cause an emergency stop.
- The reset or emergency stop condition can be obtained also by using the remote reset with the same modalities.
- The number of reset attempts is limited to a maximum of 5 within 15 minutes.

Error / RFGO LED lock-out Codes

During an alarm condition, the status LED becomes steady red. The remaining LEDs turn on according to a coded sequence which identifies the lock-out cause.

The following table shows the different LED Lock-out codes.



The device described in this manual can cause material problems, severe injuries or death.

It is the owner or user's responsibility to make sure that the equipment described is installed, used and commissioned in compliance with the requirements provided both by national and local law. The lock-out condition indicates the presence of a fault which occurred during the operating cycle or during stand-by mode.

Before performing an unlock attempt, it is necessary to restore the original optimal operating conditions.



Thermal unit's operation, maintenance and troubleshooting interventions must be carried out by trained personnel.

The persons who solve lock-out problems or reset the control device must observe the error codes to solve the problems described in this product technical data sheet.

It is not admitted to tamper with or act on the system or control in a way that could compromise the product safety or warranty.

Any tests on safety devices or on loads, such as fan motor, valves, igniter, flame sensors, must be performed with the shut-off valves closed and by qualified personnel.

Do not by-pass nor exclude the safety devices connected to the flame control.

Failure to observe these guidelines will exclude any liability.







The regulation prohibits the system from allowing more than 5 remote reset attempts within a 15 minute time window.

If more than 5 attempts are performed without solving the lock-out, the system will prevent the user to perform further remote resets and force him/her to wait for the 15 minutes to elapse.

The remote reset operation will be restored at the end of the waiting time.

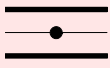
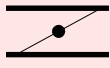
It is recommended that qualified personnel evaluate the lock-out condition and implement the solution which is suitable for the fault to be solved.

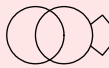
Error / RFGO LED lock-out codes

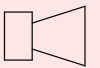
| No | Faults | LED 1 | LED 2 | LED 3 | LED 4 | LED 5 | LED 6 | LED 7 |
|----|---|---|---|---|---|---|---|---|
| | Operation LED ● = ON | Fan | Open damper | Closed damper | Auto | Ignition | Flame | Status |
| | Icon |  S9740 |  S9741 |  S9742 |  S9743 |  S9744 |  S9745 |  S9746 |
| 1 | Post-diagnostics fault | ● | | | | | | Red |
| 2 | Local reset | | ● | | | | | Red |
| 3 | Combustion air fan fault | ● | ● | | | | | Red |
| 4 | Supervisor processor diagnostics fault | | | ● | | | | Red |
| 5 | FR- NO Flame at the end of the 2 nd safety time (MTFI) | ● | | ● | | | | Red |
| 6 | FR: internal circuit fault | | ● | ● | | | | Red |
| 7 | Internal communication fault | ● | ● | ● | | | | Red |
| 8 | Remote reset | | | | ● | | | Red |
| 9 | FR: internal fault | ● | | | ● | | | Red |
| 10 | Main processor fault | | ● | | ● | | | Red |
| 11 | Data memory test fault | ● | ● | | ● | | | Red |
| 12 | Data memory test fault | | | ● | ● | | | Red |
| 13 | Mains voltage or frequent fault | ● | | ● | ● | | | Red |
| 14 | Internal processor fault | | ● | ● | ● | | | Red |
| 15 | Internal processor fault | ● | ● | ● | ● | | | Red |
| 16 | No flame: 1 st safety time (PTFI) | ● | | | | ● | | Red |
| 17 | Wiring fault | | ● | | | ● | | Red |
| 18 | Safety relay fault | ● | ● | | | ● | | Red |
| 19 | Combustion airflow switch fault in the rest position | | | ● | | ● | | Red |
| 20 | UV: no flame at the end of the 2 nd safety time (MTFI) | ● | | ● | | ● | | Red |
| 21 | Safety relay fault | | ● | ● | | ● | | Red |
| 22 | Supervisor processor fault | ● | ● | ● | | ● | | Red |
| 23 | Supervisor memory test fault | | | | ● | ● | | Red |
| 24 | Flame loss during the operation (AUTO) | ● | | | ● | ● | | Red |
| 25 | Supervisor processor data memory fault | | ● | | ● | ● | | Red |
| 26 | Supervisor processor internal fault | ● | ● | | ● | ● | | Red |
| 27 | Not used | | | | | | | |
| 28 | Not used | | | | | | | |
| 29 | Operating temperature out of range | | ● | ● | ● | ● | | Red |
| 30 | Code memory fault | ● | ● | ● | ● | ● | | Red |
| 31 | FR: external short circuit | | | | | | ● | Red |
| 32 | Check mode timeout (manual) | ● | | | | | ● | Red |
| 33 | False flame in stand-by mode | | ● | | | | ● | Red |
| 34 | Not used | | | | | | | |
| 35 | Internal processor timeout | | | ● | | | ● | Red |
| 36 | Internal processor timeout | ● | | ● | | | ● | Red |
| 37 | Combustion air check timeout | | ● | ● | | | ● | Red |
| 38 | Internal processor timeout | ● | ● | ● | | | ● | Red |
| 39 | Internal processor timeout | | | | ● | | ● | Red |
| 40 | Internal hardware fault | ● | | | ● | | ● | Red |
| 41 | Internal hardware fault | | ● | | ● | | ● | Red |
| 42 | Main processor fault | ● | ● | | ● | | ● | Red |
| 43 | Supervisor processor fault | | | ● | ● | | ● | Red |
| 44 | Supervisor processor timeout | ● | | ● | ● | | ● | Red |
| 45 | Off-specification mains voltage | | ● | ● | ● | | ● | Red |

| No | Faults | LED 1 | LED 2 | LED 3 | LED 4 | LED 5 | LED 6 | LED 7 |
|----|--|-------|-------|-------|-------|-------|-------|-------|
| 46 | Off-specification mains voltage | • | • | • | • | | • | Red |
| 47 | UV: Internal fault | | | | | • | • | Red |
| 48 | Supervisor processor fault | • | | | | • | • | Red |
| 49 | Main processor fault | | • | | | • | • | Red |
| 50 | Ignition feedback fault | • | • | | | • | • | Red |
| 51 | Pilot feedback fault | | | • | | • | • | Red |
| 52 | Piloted valve feedback fault | • | | • | | • | • | Red |
| 53 | Actuator feedback waiting time expired | | • | • | | • | • | Red |
| 54 | Direct ignition valve feedback fault | • | • | • | | • | • | Red |
| 55 | Internal processor fault | | | | • | • | • | Red |
| 56 | UV: false flame during operation | | | • | • | • | • | Red |
| 57 | FR: false flame during operation | • | | • | • | • | • | Red |
| 58 | T8 inlet fault | | • | • | • | • | • | Red |
| 59 | Internal hardware fault | • | | | • | • | • | Red |
| 60 | Local reset fault | • | • | • | • | • | • | Red |
| 61 | Open POC fault | | • | | • | • | • | Red |
| 62 | UV: strong UV flame fault | • | • | | • | • | • | Red |
| 63 | Internal hardware fault | | | | | • | | Red |

Tab. O

Fault explanation

| No | Faults | Cause | Solution |
|----|---|--|---|
| 1 | Post-diagnostics fault | Initial power diagnostics fault Make sure that the status of inlets and outlets is correct upon ignition | Check T12, T13 and T14 |
| 2 | Local reset | The user started the manual reset or the reset switch is faulty | Check T21 inlet or reset for normal operation |
| 3 | Combustion air fan fault | No Air Check signal (T14) during the bleed cycle or Air Check signal loss during the burner operation | Check the fan or the air pressure switch |
| 4 | Supervisor processor diagnostics fault | The system detected the presence of voltage on T16, T17, T18 or T19 at the wrong moment or there is no voltage when necessary | Check the wiring and make sure that the system is operating on a single-phase line (50/60Hz) |
| 5 | FR- No flame at the end of the 2 nd safety time (MTFI) | No flame at the end of the second safety time | Inspect the system, check the gas pressure, inspect the flame detection electrode, check the wiring, etc. |
| 6 | FR: internal circuit fault | Internal fault | Replace the control device |
| 7 | Internal communication fault | Internal fault | Replace the control device |
| 8 | Remote reset | The user pressed the remote reset button or the reset switch is discontinuous/dynamic | Check the remote switch |
| 9 | FR: internal fault | Internal fault | Replace the control device |
| 10 | Main processor fault | Internal fault | Replace the control device |
| 11 | Data memory test fault | Internal fault | Replace the control device |
| 12 | Data memory test fault | Internal fault | Replace the control device |
| 13 | Mains voltage or frequent fault | Off-specification power supply voltage and/or frequency | Check the input power supply |
| 14 | Internal processor fault | Internal fault | Replace the control device |
| 15 | Internal processor fault | Internal fault | Replace the control device |
| 16 | No flame: 1 st safety time (PTFI) | No flame at the end of the first safety time | Inspect the system, check the gas pressure, check the UV scanner, check the wiring, etc. |
| 17 | Wiring fault | The system detected the presence of voltage on critical terminals (T16, T17, T18 or T19) at the wrong moment or there is no voltage when necessary | Inspect the wiring and make sure that the system is operating on a single-phase line (50/60Hz) |
| 18 | Safety relay fault | Internal fault | Replace the control device |
| 19 | Combustion airflow switch fault in the rest position | Open the circuit upon T13 start-up | Check the wiring for the air pressure switch |

| No | Faults | Cause | Solution |
|----|---|--|---|
| 20 | UV: no flame at the end of the 2 nd safety time (MTFI) | No flame at the end of the 2 nd safety time | Inspect the system, check the gas pressure, check the UV scanner, check the wiring, etc. |
| 21 | Safety relay fault | Internal fault | Replace the control device |
| 22 | Supervisor processor fault | Internal fault | Replace the control device |
| 23 | Supervisor memory test fault | Internal fault | Replace the control device |
| 24 | Flame loss during the operation (AUTO) | Loss of flame | Check the scanner or the fuel flow line |
| 25 | Supervisor processor data memory fault | Internal fault | Replace the control device |
| 26 | Supervisor processor internal fault | Internal fault | Replace the control device |
| 27 | Not used | | |
| 28 | Not used | | |
| 29 | Operating temperature out of range | Operating temperature below -40°C or above 70°C | Bring the control device within the specified temperature nominal values |
| 30 | Code memory fault | Internal fault | Replace the control device |
| 31 | FR: external short circuit | External short circuit between T24 and EARTH | Inspect the flame detection electrode |
| 32 | Check mode timeout (manual) | The interval for the manual mode (30 minutes) to end has elapsed | Exit the manual mode correctly to avoid timeout |
| 33 | False flame in stand-by mode | Unexpected flame (false or parasitic flame) detected during the Stand-by status | Check scanner or interference |
| 34 | Not used | | |
| 35 | Internal processor timeout | Internal fault | Replace the control device |
| 36 | Internal processor timeout | Internal fault | Replace the control device |
| 37 | Combustion air check timeout | The system could not perform verification tests of the combustion air during the burner sequence | Check the wiring or the air pressure switch |
| 38 | Internal processor timeout | Internal fault | Replace the control device |
| 39 | Internal processor timeout | Internal fault | Replace the control device |
| 40 | Internal hardware fault | Internal fault | Replace the control device |
| 41 | Internal hardware fault | Internal fault | Replace the control device |
| 42 | Main processor fault | Internal fault | Replace the control device |
| 43 | Supervisor processor fault | Internal fault | Replace the control device |
| 44 | Supervisor processor timeout | Internal fault | Replace the control device |
| 45 | Off-specification mains voltage | Off-specification mains voltage/frequency | Check the mains voltage level or the frequency. Contact the factory if the problem persists |
| 46 | Off-specification mains voltage | Off-specification mains voltage/frequency | Check the mains voltage level or the frequency. Contact the factory if the problem persists |
| 47 | UV: Internal fault | Internal fault | Replace the control device |
| 48 | Supervisor processor fault | Internal fault | Replace the control device |
| 49 | Main processor fault | Internal fault | Replace the control device |
| 50 | Ignition feedback fault | The system detected the presence of voltage on T16 at the wrong moment or there is no voltage when necessary | Check the wiring and make sure that the earthing is appropriate If the problem persists, contact the distributor/factory |
| 51 | Pilot feedback fault | The system detected the presence of voltage on T17 at the wrong moment or there is no voltage when necessary | Check the wiring and make sure that the earthing is appropriate. If the problem persists, contact the distributor/factory |
| 52 | Piloted valve feedback fault | The system detected the presence of voltage on T19 at the wrong moment or there is no voltage when necessary | Check the wiring and make sure that the earthing is appropriate If the problem persists, contact the distributor/factory |
| 53 | Actuator feedback waiting time expired | No actuator feedback on T8 for more than 10 minutes | Check the wiring Check the modulation equipment |
| 54 | Direct ignition valve feedback fault | The system detected the presence of voltage on T18 at the wrong moment or there is no voltage when necessary | Check the wiring and make sure that the earthing is appropriate. If the problem persists, contact the distributor/factory |

| No | Faults | Cause | Solution |
|----|----------------------------------|---|--|
| 55 | Internal processor fault | Internal fault | Replace the control device |
| 56 | UV: false flame during operation | False flame detected before ignition | Check the scanner |
| 57 | FR: false flame during operation | False flame detected before ignition | Check the wiring Check the scanner Make sure that earthing is appropriate |
| 58 | T8 inlet fault | The system detected the presence of voltage on T8 at the wrong moment or there is no voltage when necessary | Check the wiring Check the actuator |
| 59 | Internal hardware fault | Internal fault | Replace the control device |
| 60 | Local reset fault | Local reset button pressed for more than 10 seconds or reset button locked | If the problem persists, replace the control device |
| 61 | Open POC fault | The fuel valve is open at the wrong moment | Check the wiring |
| 62 | UV: strong UV flame fault | The scanner is too close to the flame | Increase the distance between the scanner and the flame OR use an orifice to reduce the view field |
| 63 | Internal hardware fault | Internal fault | Replace the control device |

Tab. P

A Appendix - Accessories**Extended head Kit (for short head versions only)**

| Burner | L (mm) | | Code |
|----------|---------------|------------------------------|---------|
| | Standard head | Head obtainable with the kit | |
| RL 70/M | 272 | 385 | 3010159 |
| RL 100/M | 272 | 385 | 3010160 |
| RL 130/M | 370 | 526 | 3010161 |

Soundproofing box kit

| Burner | Type | dB(A) | Code |
|------------|------|-------|---------|
| All models | C4/5 | 10 | 3010404 |

Degasser kit

| Burner | Filter | Code |
|------------|----------------|---------|
| All models | with filter | 3010055 |
| All models | without filter | 3010054 |

Kit for modulation operation

Two components should be ordered:

- the output regulator to install on the burner;
- the probe to install on the heat generator.

| PARAMETER TO BE CHECKED | Range | PROBE | | POWER REGULATOR | |
|-------------------------|------------------|--------------------------------|---------|-----------------|----------------------|
| | | Type | Code | Type | Code |
| Temperature | - 100...+ 500 °C | PT 100 | 3010110 | RWF50 RWF55 | 20082208 20099657 |
| Pressure | 0...2,5 bar | Probe with output 4...20 mA | 3010213 | | |
| | 0...16 bar | | 3010214 | | |
| | 0...25 bar | | 3090873 | | |

Spacer kit

| Burner | Code |
|------------|---------|
| All models | 3010129 |

Potentiometer kit

| Burner | Code |
|------------|---------|
| All models | 3010416 |

Head kit for “reverse flame chamber”

| Burner | Code |
|-------------|---------|
| RL 70-100/M | 3010180 |
| RL 130/M | 3010183 |

Gas trains in compliance with EN 676

Please refer to manual.



ATTENTION

The installer is responsible for the addition of any safety device not foreseen in this manual.

B Appendix - Electrical panel layout

| | |
|----------|--|
| 1 | Index of layouts |
| 2 | Indication of references |
| 3 | RFGO-A23 operational layout |
| 4 | RFGO-A23 operational layout |
| 5 | Electrical connection set by the installer |
| 6 | RWF operational layout |

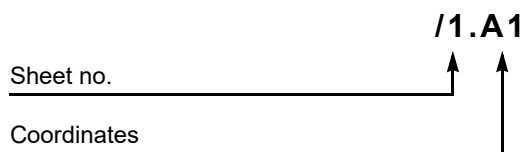
2 Indication of references

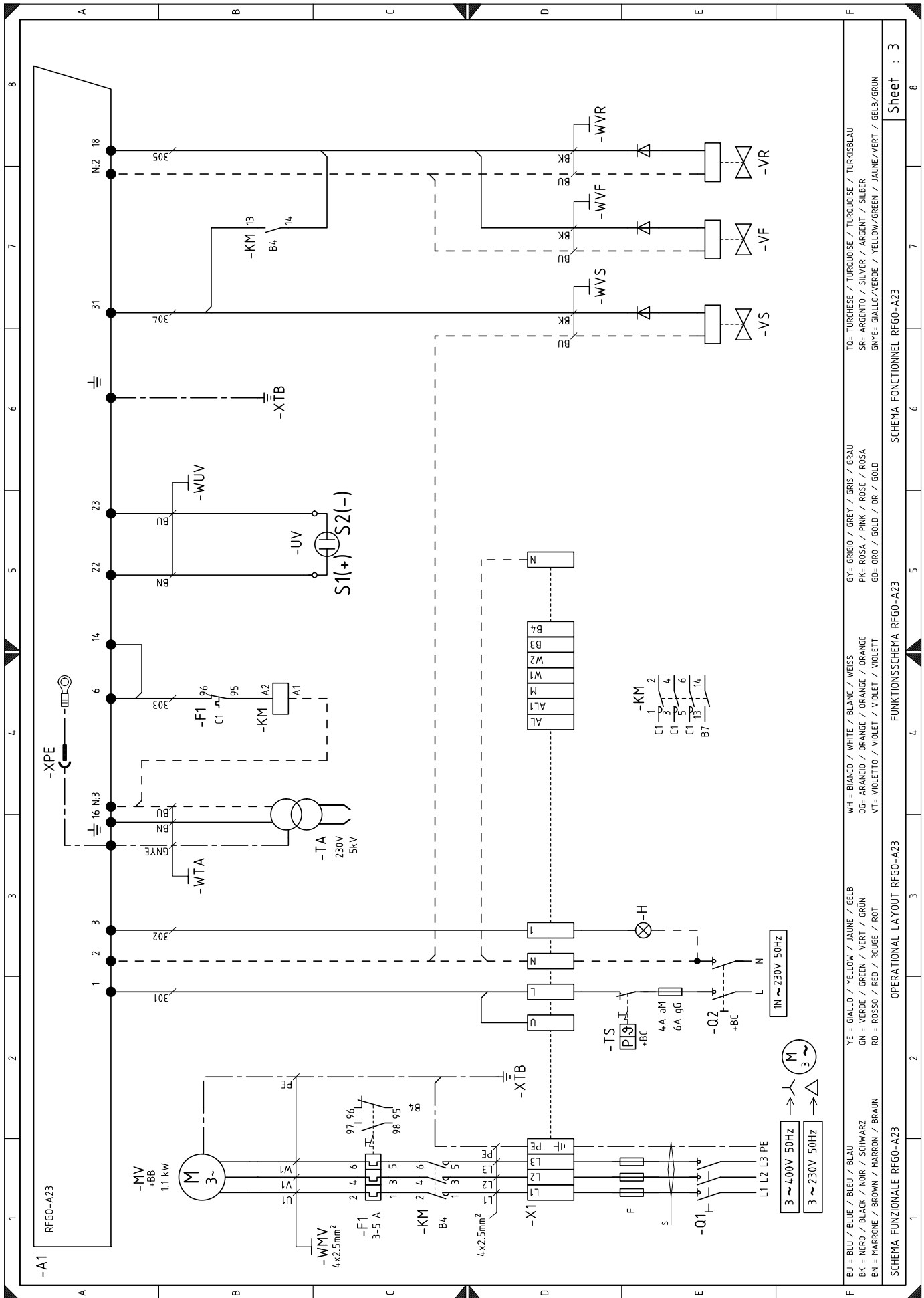

BU = BLU / BLUE / BLEU / BLAU
 BK = NERO / BLACK / NOIR / SCHWARZ
 BN = MARRONE / BROWN / MARRON / BRAUN
 YE = GIALLO / YELLOW / JAUNE / GELB
 GN = VERDE / GREEN / VERT / GRÜN
 RD = ROSSO / RED / ROUGE / ROT
 WH = BIANCO / WHITE / BLANC / WEISS
 OG = ARANCIO / ORANGE / ORANGE / ORANGE
 VT = VIOLETTA / VIOLET / VIOLET / VIOLETT
 GY = GRIGIO / GREY / GRIS / GRAU
 PK = ROSA / PINK / ROSE / ROSA
 GD = ORO / GOLD / OR / GOLD
 TO = TURCHESE / TURQUOISE / TURQUOISE / TURKISBLAU
 SR = ARGENTO / SILVER / ARGENT / SILBER
 GNYE = GIALLO/VERDE / YELLOW/GREEN / JAUNE/VERT / GELB/GRÜN

SCHEMA FUNZIONALE RFGO-A23
 OPERATIONAL LAYOUT RFGO-A23
 FUNKTIONSSSCHEMA RFGO-A23
 SCHEMA FONCTIONNEL RFGO-A23
 Sheet : 3

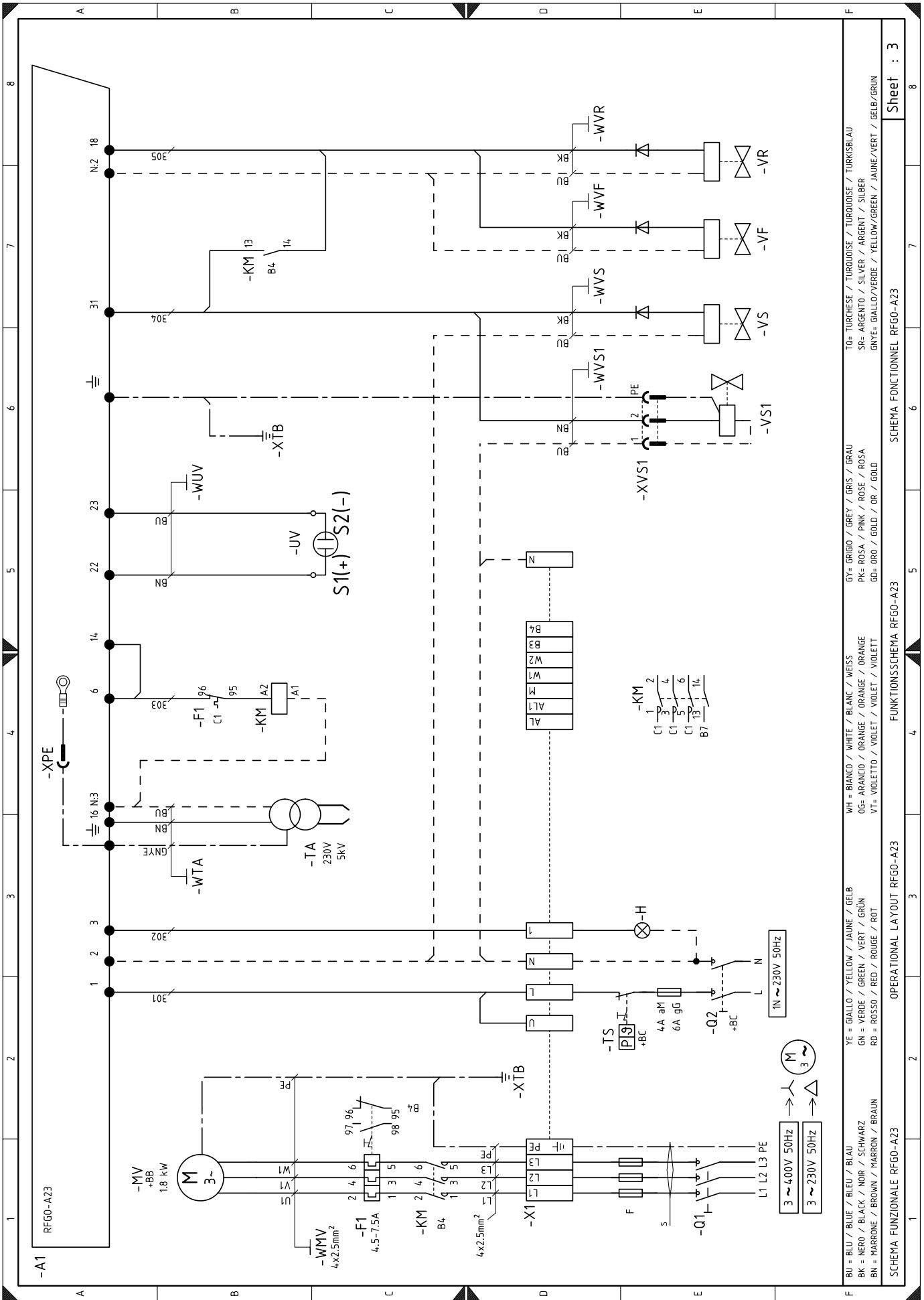

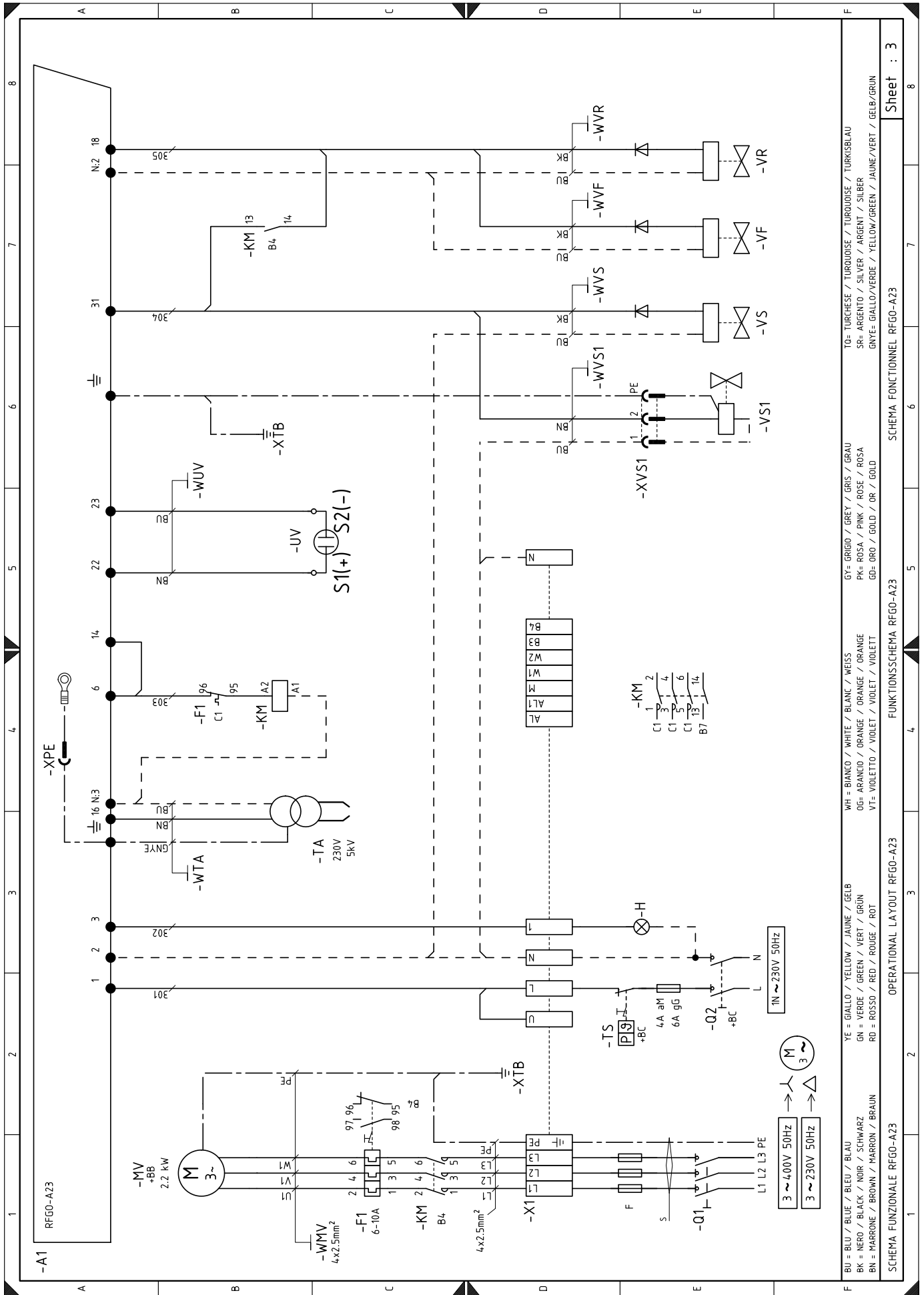

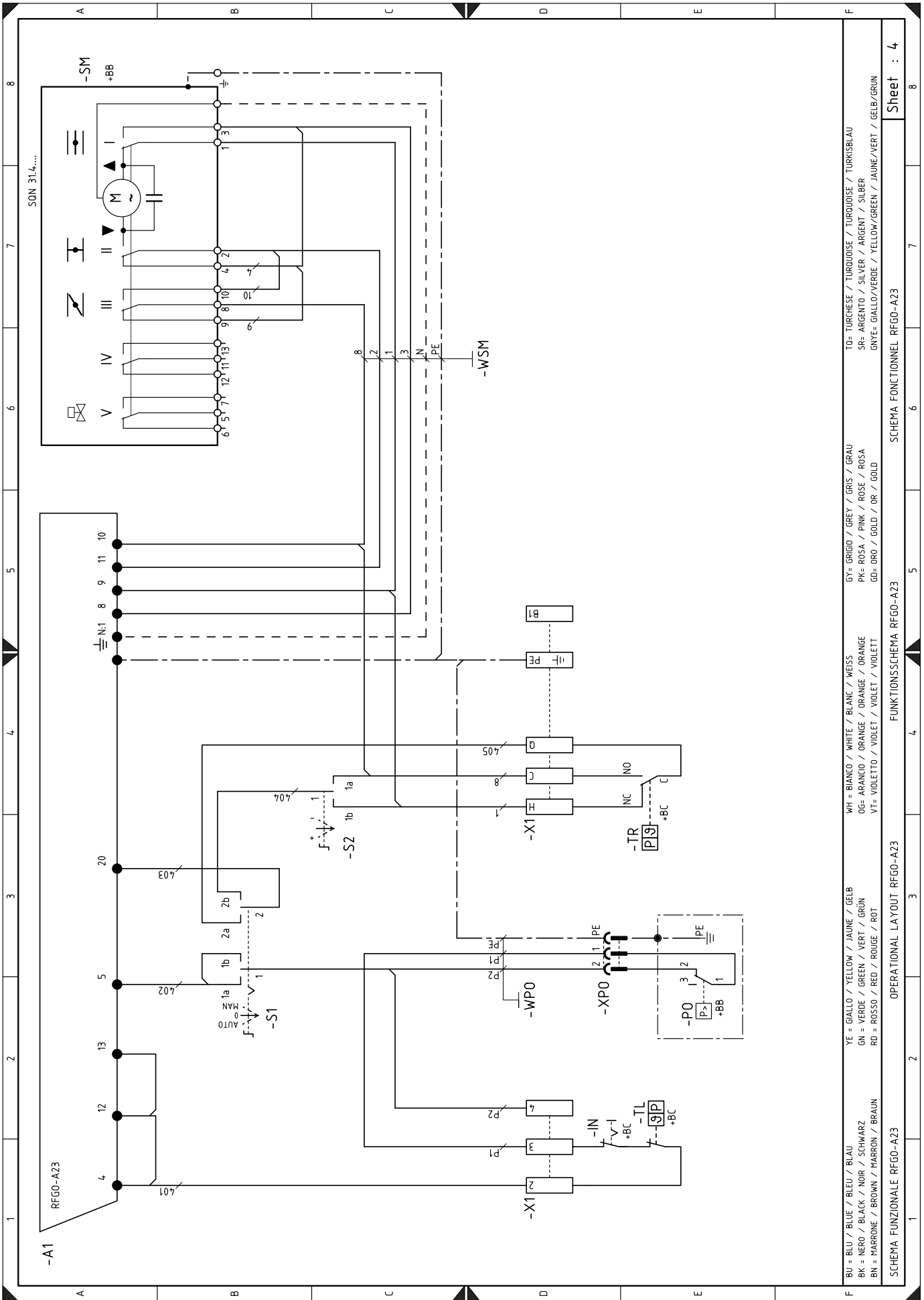

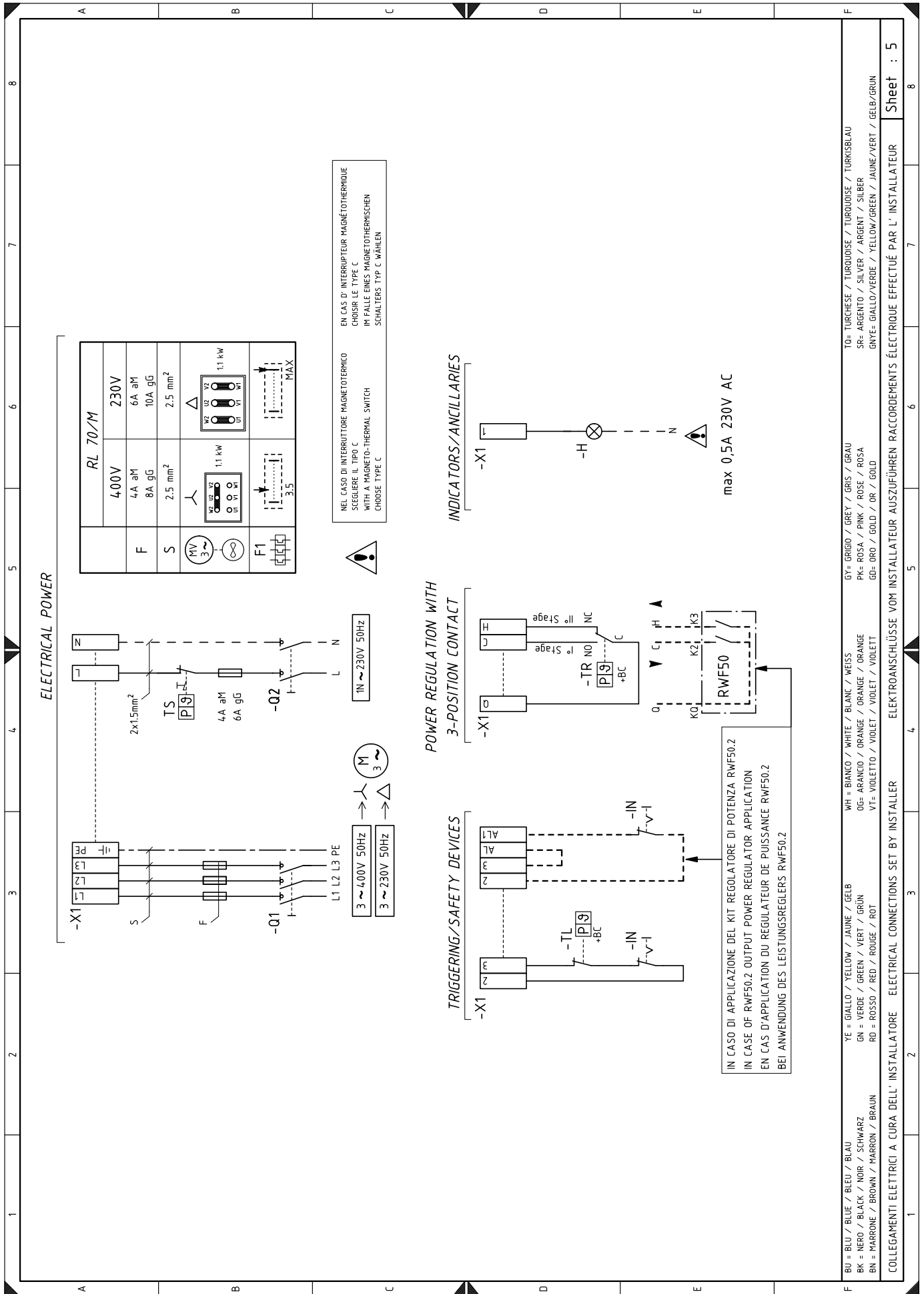

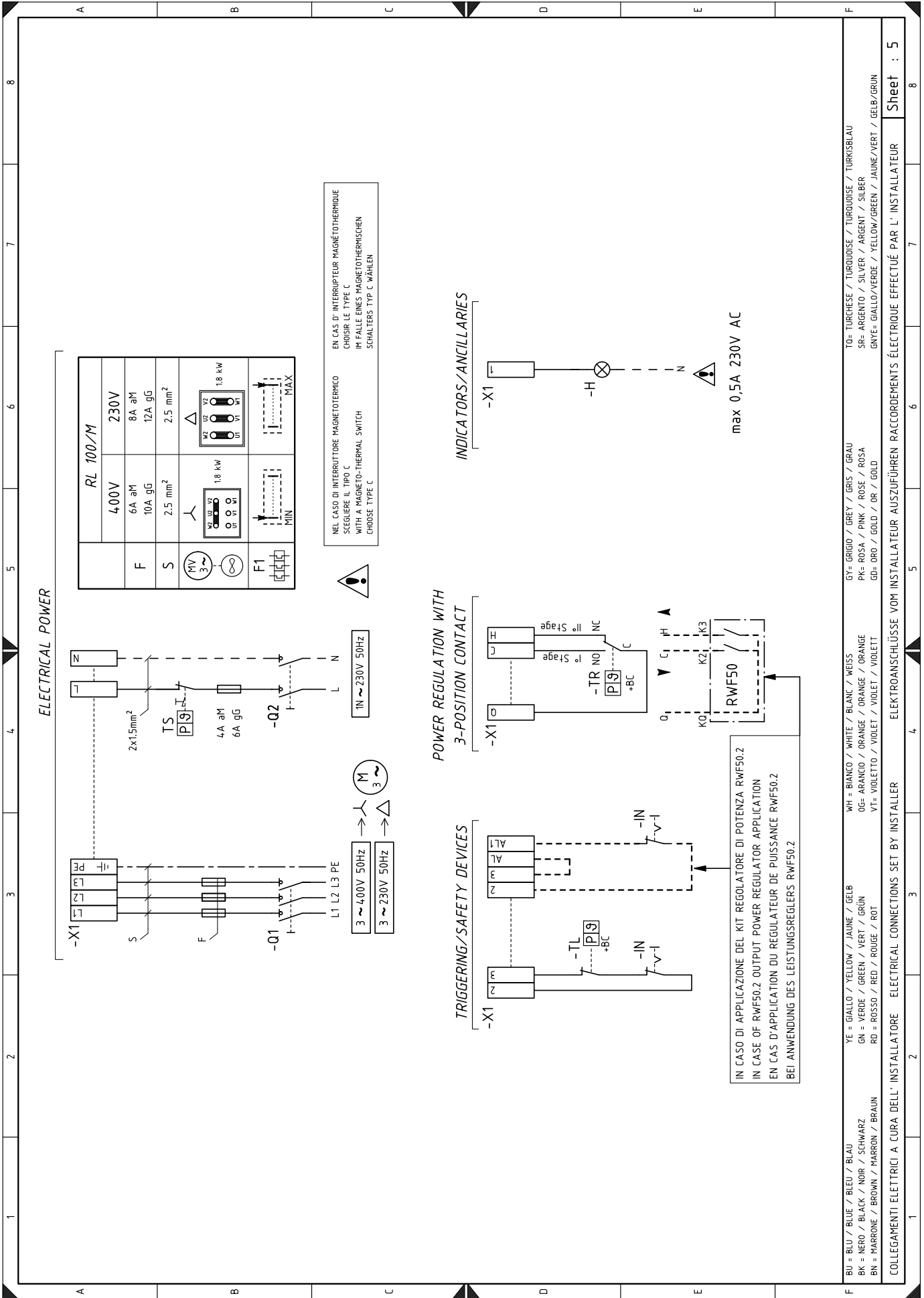

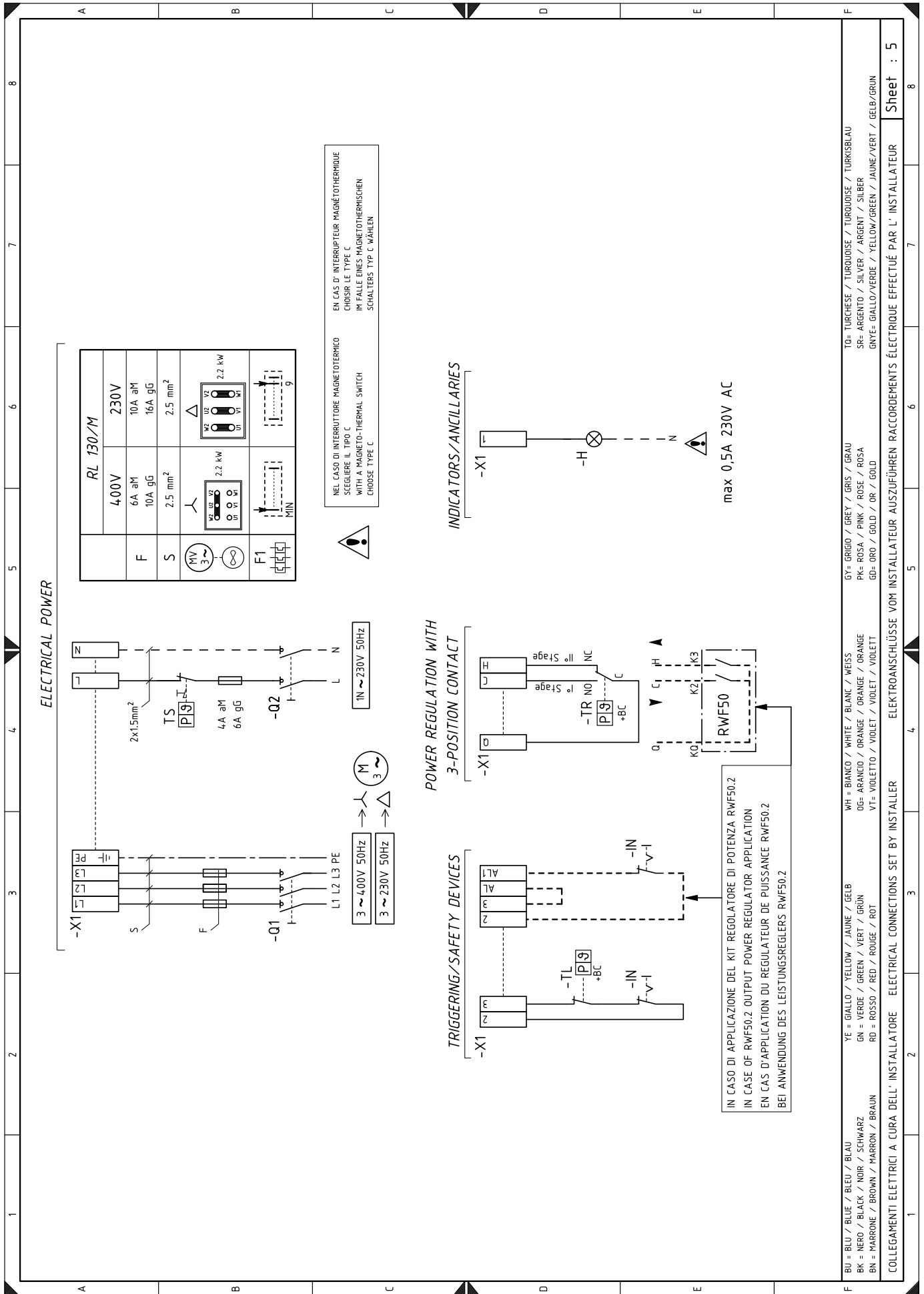

| | | | | |
|---------------------------------------|-------------------------------------|---|----------------------------------|---|
| BU = BLU / BLUE / BLEU / BLAU | YE = GIALLO / YELLOW / JAUNE / GELB | WH = BIANCO / WHITE / BLANC / WEISS | GY = GRIGIO / GREY / GRIS / GRAU | TO = TURCHESE / TURQUOISE / TURKOISE / TURKISBLAU |
| BK = NERO / BLACK / NOIR / SCHWARZ | GN = VERDE / GREEN / VERT / GRÜN | OG = ARANCIO / ORANGE / ORANGE / ORANGE | PK = ROSA / PINK / ROSE / ROSA | SR = ARGENTO / SILVER / ARGENT / SILBER |
| BN = MARRONE / BROWN / MARRON / BRAUN | RD = ROSSO / RED / ROUGE / ROT | VI = VIOLETTA / VIOLET / VIOLET / VIOLETT | GD = ORO / GOLD / OR / GOLD | GNTE = GIALLO/VERDE / YELLOW/GREEN / JAUNE/VERT / GELB/GRÜN |

ELEKTROANSCHLÜSSE VOM INSTALLATEUR AUSZUFÜHREN RACCORDEMENTS ÉLECTRIQUE EFFECTUÉ PAR L'INSTALLATEUR

Sheet : 5

WIRING DIAGRAM KEY

| | |
|-------|---|
| A1 | Control box |
| F | Protection fuses for three line |
| F1 | Thermal relay for fan motor |
| H | Remote lockout signal |
| B1 | RWF power modulator |
| BA | Probe with current output |
| BA1 | Device with current output for editing remote setpoint |
| BP | Pressure probe |
| BP1 | Pressure probe |
| BR | Remote setpoint voltage divider |
| BT1 | Thermocouple probe |
| BT2 | Probe Pt100 with 2 wires |
| BT3 | Probe Pt100 with 3 wires |
| BT4 | Probe Pt100 with 3 wires |
| BTEXT | External probe for the climatic compensation of the setpoint |
| BV | Probe with voltage output |
| BV1 | Device with voltage output for editing remote setpoint |
| KM | Fan motor contactor |
| IN | External switch for ON/OFF burner |
| MV | Fan motor |
| SM | Servomotor |
| S1 | Operation switch: MAN = manual AUT = automatic OFF = off |
| S2 | Button for - = output decrease + = output increase |
| PO | Oil pressure switch |
| XPO | Connector for oil pressure switch |
| TA | Ignition transformer |
| TL | Limit thermostat |
| TR | Adjustment thermostat |
| TS | Safety thermostat |
| UV | UV flame sensor |
| VR | Adjustment valve |
| VS | Safety valve |
| VF | Operation valve |
| VS1 | Safety valve |
| XVS1 | Safety valve connector |
| XPE | Control box earth |
| XTB | Burner earth |
| X1 | Terminal board |

RIELLO

RIELLO S.p.A.
I-37045 Legnago (VR)
Tel.: +39.0442.630111
[http:// www.riello.it](http://www.riello.it)
[http:// www.riello.com](http://www.riello.com)