

Modulating SuperCap rotary actuator with emergency setting function and extended functionalities for adjusting air dampers in ventilation and air-conditioning systems for building services installations and in laboratories

- For air dampers up to approx. 1.2 m<sup>2</sup>
- Torque 6 Nm
- Nominal voltage AC/DC 24 V
- Control: modulating DC 0 ... 10 V
- Position feedback DC 0 ... 10 V
- Running time 4 s
- Design life SuperCaps 15 years



### Technical data

|                        |   |   |
|------------------------|---|---|
| <b>Electrical data</b> | Nominal voltage                         | AC 24 V, 50/60 Hz / DC 24 V   |
|                        | Nominal voltage range                   | AC 19.2 ... 28.8 V / DC 21.6 ... 28.8 V   |
|                        | Power consumption                       | In operation 11 W @ nominal torque<br>At rest 3 W<br>For wire sizing 22 VA (I <sub>max</sub> 20 A @ 5 ms)                           |
|                        | Connection                              | Cable 1 m, 4 x 0.75 mm <sup>2</sup>   |
| <b>Functional data</b> | Torque                                  | ≥6 Nm   |
|                        | Inhibiting torque                       | ≥6 Nm   |
|                        | Control                                 | Control signal Y DC 0 ... 10 V, input impedance 100 kΩ<br>Operating range DC 0.5 ... 10 V   |
|                        | Position feedback (Measuring voltage U) | DC 0.5 ... 10 V, max. 0.5 mA  |
|                        | Emergency setting position (POP)        | 0 ... 100%, adjustable in increments of 10% (POP rotary button)   |
|                        | Position accuracy                       | ±5%   |
|                        | Direction of rotation                   | Motor Reversible with switch ↻ / ↺<br>Emergency setting position Reversible with switch 0 ... 100%, Adjustable in increments of 10% |
|                        | Direction of motion at Y = 0 V          | At switch position 1 ↻ or 0 ↺, respectively   |
|                        | Manual override                         | Gearing latch disengaged with push button   |
|                        | Angle of rotation                       | Max. 95°↔, can be limited at both ends with adjustable mechanical end stops   |
|                        | Angle of rotation limiting              | min. 30°↔   |
|                        | Running time                            | Motor 4 s / 90°↔<br>Emergency setting function 4 s @ 0 ... 50 °C  |
|                        | Sound power level                       | Motor ≤60 dB (A) @ 4 s running time<br>Emergency setting function ≤60 dB (A) @ 4 s running time                                     |
|                        | Position indication                     | Mechanical, pluggable   |
| <b>Safety</b>          | Protection class                        | III Safety extra-low voltage<br>UL Class 2 Supply   |
|                        | Degree of protection                    | IP54<br>NEMA 2, UL Enclosure Type 2   |
|                        | EMC                                     | CE according to 2004/108/EC   |
|                        | Certification                           | Certified to IEC/EN 60730-1 and IEC/EN 60730-2-14<br>cULus according to UL 60730-1A and UL 60730-2-14<br>and CAN/CSA E60730-1:02    |
|                        | Mode of operation                       | Type 1.AA   |
|                        | Rated impulse voltage                   | 0.8 kV  |
|                        | Control pollution degree                | 3   |

**Technical data**

(continued)

|                            |                            |
|----------------------------|----------------------------|
| Ambient temperature        | -30 ... +50 °C             |
| Non-operating temperature  | -40 ... +80 °C             |
| Ambient humidity           | 95% r.h., non-condensating |
| Maintenance                | Maintenance-free           |
| <b>Dimensions / Weight</b> |                            |
| Dimensions                 | See «Dimensions» on page 5 |
| Weight                     | Approx. 1.1 kg             |

**Safety notes**

- The actuator is not allowed to be used outside the specified field of application, especially in aircraft or in any other airborne means of transport.
- It may only be installed by suitably trained personnel. Any legal regulations or regulations issued by authorities must be observed during installation.
- The device may only be opened at the manufacturer's site. It does not contain any parts that can be replaced or repaired by the user.
- The cable must not be removed from the device.
- Adaption is necessary when the system is commissioned and after each adjustment of the angle (press the adaption push button once).
- The device contains electrical and electronic components and is not allowed to be disposed of as household refuse. All locally valid regulations and requirements must be observed.

**Product features**
**Mode of operation**

The actuator moves the air damper to the desired operating position at the same time as the integrated capacitors are loaded. Interrupting the supply voltage causes the air damper to be rotated back into the emergency setting position by means of stored electrical energy. The actuator is controlled with a standard modulating signal of DC 0 ... 10 V and travels to the position defined by the control signal. The measuring voltage U serves for the electrical display of the damper position 0 ... 100%.

**Pre-charging time (start up)**

The capacitor actuators require a pre-charging time. This time is used for charging the capacitors up to a usable voltage level. This ensures that, in the event of a voltage interruption, the actuator can be moved at any time from its current position into the preset emergency setting position (POP).

The duration of the pre-charging time depends mainly on how long the power was interrupted.

Typical pre-charging times

| Pre-charging time [s] | Duration of voltage interruption [Days] |    |    |    |     |
|-----------------------|---|----|----|----|-----|
|                       | 0                                       | 1  | 2  | 7  | ≥10 |
|                       | 9                                       | 10 | 11 | 13 | 15  |

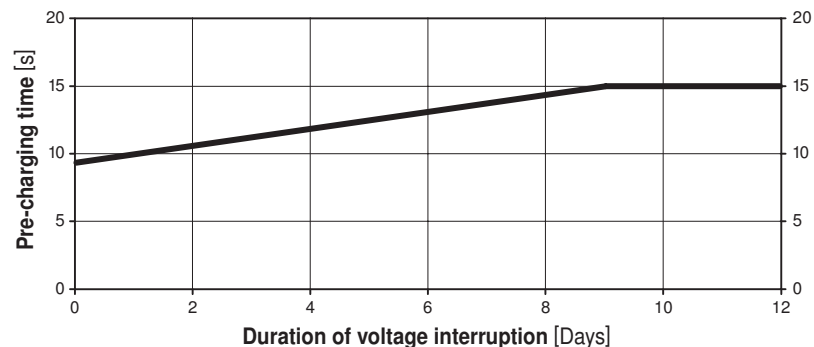
**Delivery condition (capacitors)**

The actuator is completely discharged after delivery from the factory, which is why the actuator requires approximately 15 s pre-charging time before initial commissioning in order to bring the capacitors up to the required voltage level.

**Simple direct mounting**

Simple direct mounting on the damper spindle with a universal spindle clamp, supplied with an anti-rotation strap to prevent the actuator from rotating.

**Manual override**

Manual override with push button possible (the gear is disengaged for as long as the button remains pressed down).

**High functional reliability**

The actuator is overload-proof, requires no limit switches and automatically stops when the end stop is reached.

**Product features**

(continued)

|   |   |
|---|---|
| <b>Home position / Start</b>                          | The spindle clamp of the actuator is set ex-works to 0°↵. After the supply voltage has been applied, the actuator moves into the position defined by the control signal.  |
| <b>Direction of rotation switch</b>                   | When actuated, the direction of rotation switch changes the running direction in normal operation.<br>The direction of rotation switch has no influence on the emergency setting position (POP) which has been set.   |
| <b>Emergency setting position (POP) rotary button</b> | The «Emergency setting position» rotary button can be used to adjust the desired emergency setting position (POP) between 0 and 100% in 10% increments.<br>The rotary button is always in reference to the adapted angle of rotation range.<br>In the event of a voltage interruption, the actuator will move immediately into the selected emergency setting position.                   |
| <b>Adjustable angle of rotation</b>                   | Adjustable angle of rotation with mechanical end stops.<br>A minimum permissible angle of rotation of 30°↵ must be allowed for.   |
| <b>Adaption and synchronisation</b>                   | With the adaption, the upper and lower spindle end stops are detected and stored in the actuator. The detection of the mechanical end stops makes it possible to have a gentle approach of the end positions, thus protecting the actuator mechanics.<br>During synchronization, the actuator moves into home position for angle referencing. This ensures a correct position modulation. |

**Accessories**

|                               | Description  | Data sheet      |
|-------------------------------|--|-----------------|
| <b>Electrical accessories</b> | Auxiliary switch S..A..  | T2 - S..A..     |
|                               | Feedback potentiometer P..A..  | T2 - P..A..     |
|                               | Adapter Z-SPA  |                 |
|                               | This adapter must be ordered if an auxiliary switch or a feedback potentiometer is required. |                 |
|                               | Positioner SGA24, SGE24 and SGF24  | T2 - SG..24     |
| <b>Mechanical accessories</b> | Digital position indicator ZAD24   | T2 - ZAD24      |
|                               | Room temperature controller CR24..   | S4 - CR24..     |
|                               | Various accessories  | T2 - Z-NKQ..A.. |

**Electrical installation**

**Wiring diagram**

**Note**

Connect via safety isolation transformer.

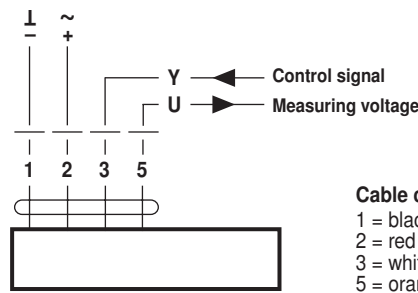

**Wiring diagram for parallel operation**

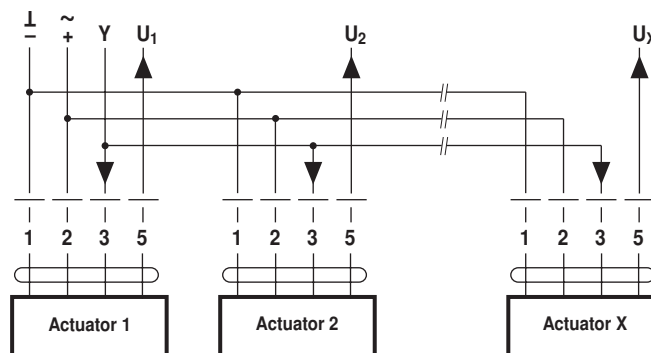

**Information**

- A maximum of eight actuators can be connected in parallel.
- Parallel operation is permitted only on separated axes.
- It is imperative that the performance data be observed with parallel operation.

Operating controls and indicators

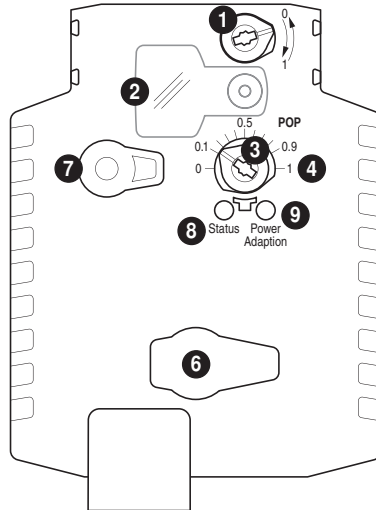

- 1 Direction of rotation switch
- 2 Cover, POP button
- 3 POP button
- 4 Scale for manual adjustment
- 6 (no function)
- 7 Disengagement button

| LED displays |             | Meaning / function           |
|--------------|-------------|------------------------------|
| 8 yellow     | 9 green     |                              |
| Off          | Illuminated | Operation OK / without fault |
| Off          | Blinking    | POP function active          |
| Illuminated  | Off         | Fault                        |
| Off          | Off         | Not in operation             |
| Illuminated  | Illuminated | Adaptation procedure running |

- 9 Press button: Triggers angle of rotation adaption, followed by standard operation

Einstellung der Notstellposition (POP)

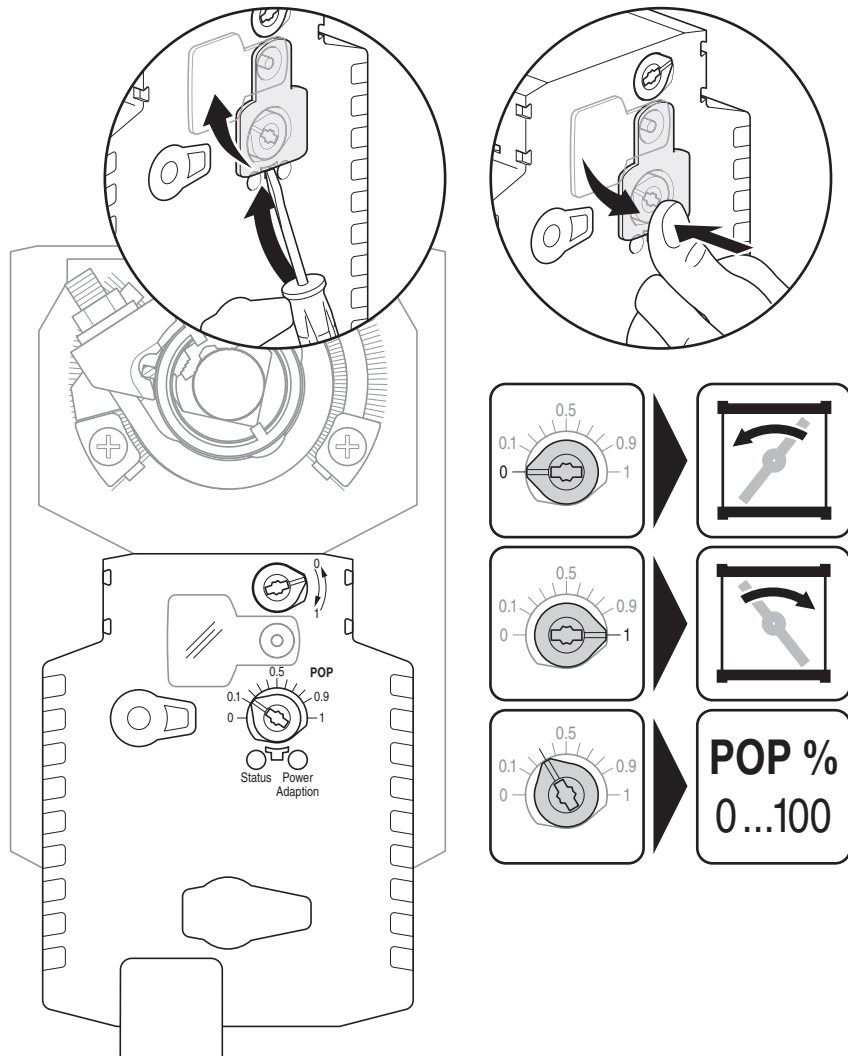

Dimensions [mm]

Dimensional drawings

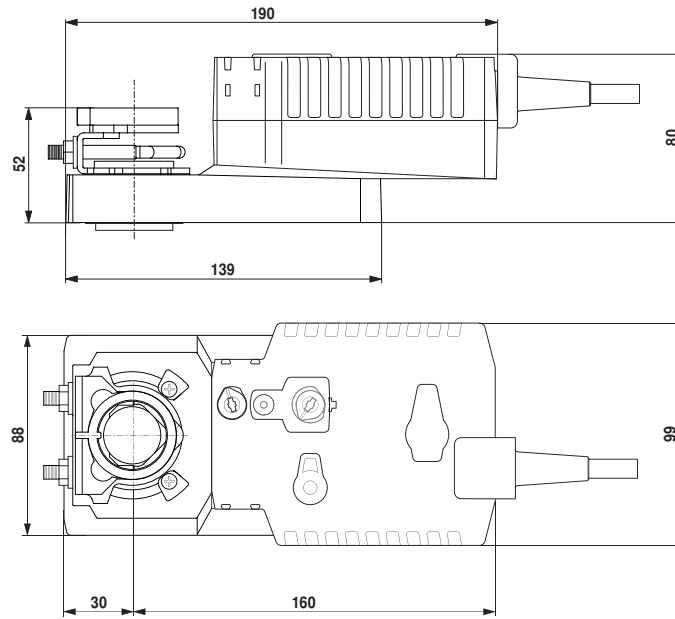

| Damper spindle | Length | ● I        | ■ I | ◆ I   |
|----------------|--------|------------|-----|-------|
|                | ≥42    | 8 ... 26.7 | ≥8  | ≤26.7 |
|                | ≥20    | 8 ... 20   | ≥8  | ≤20   |

\* Option (Accessories K-SA)  
When an auxiliary switch or a feedback potentiometer is used, see «Accessories»

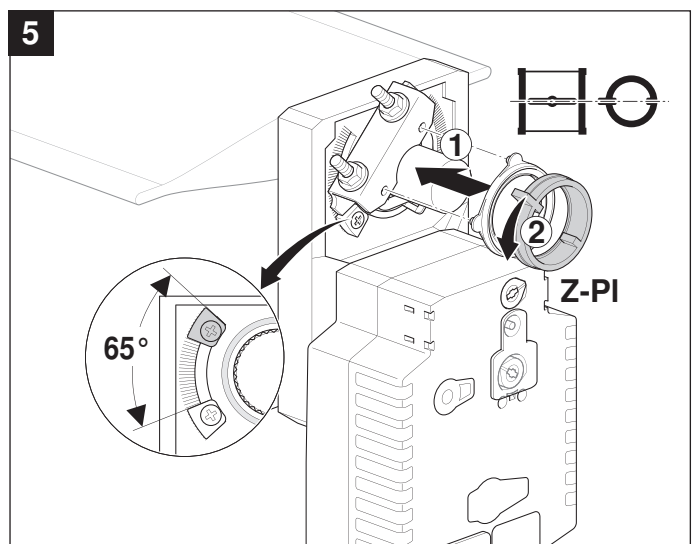
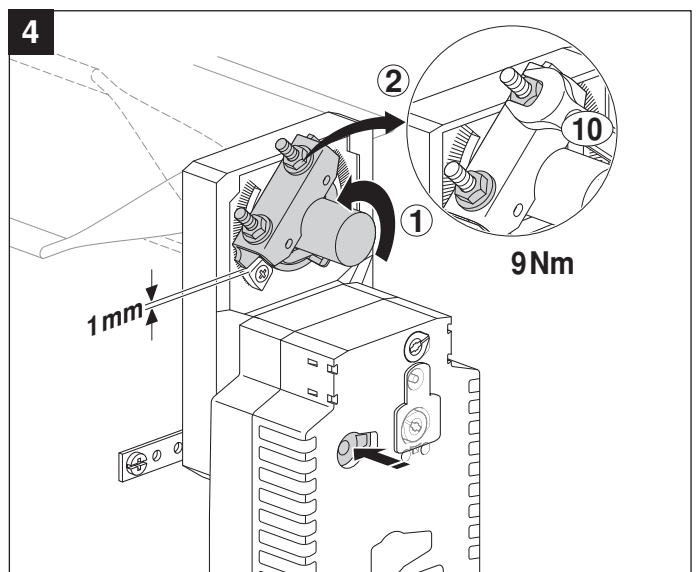
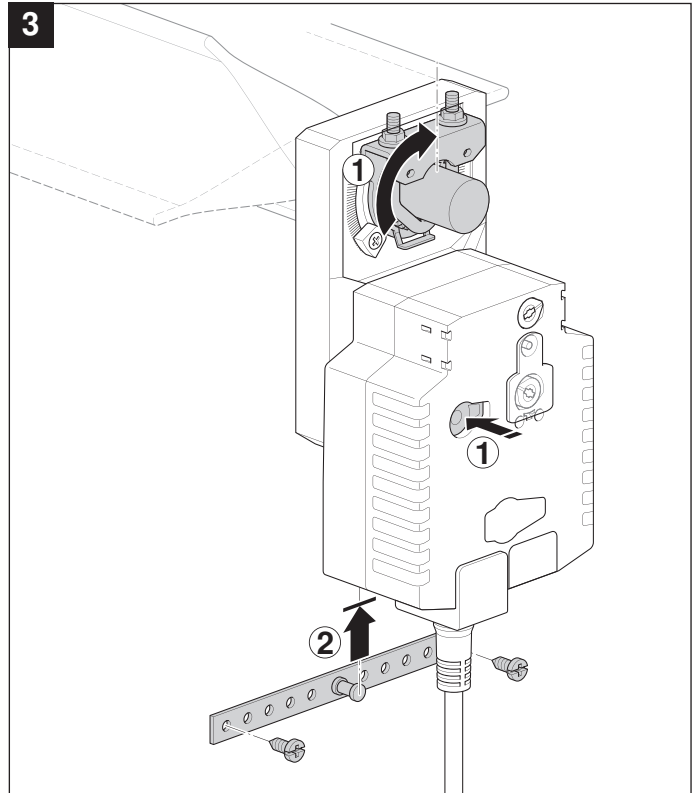
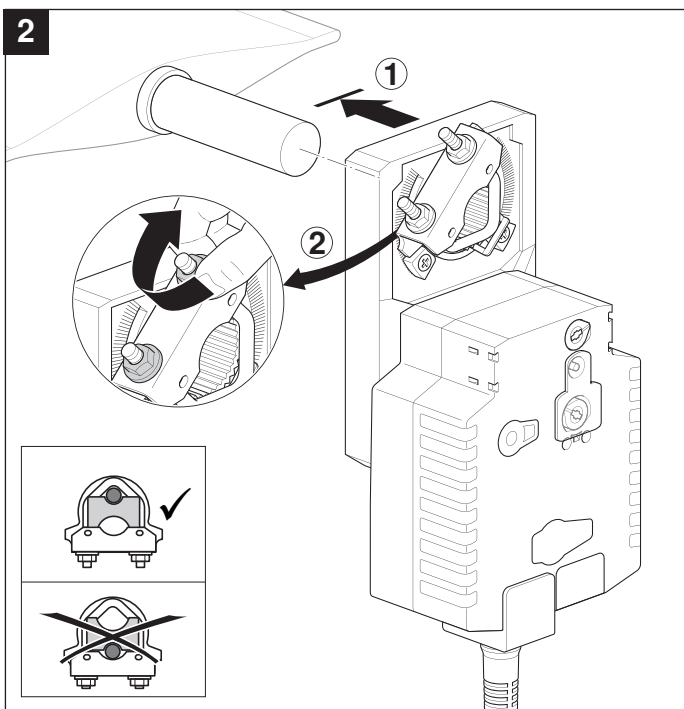
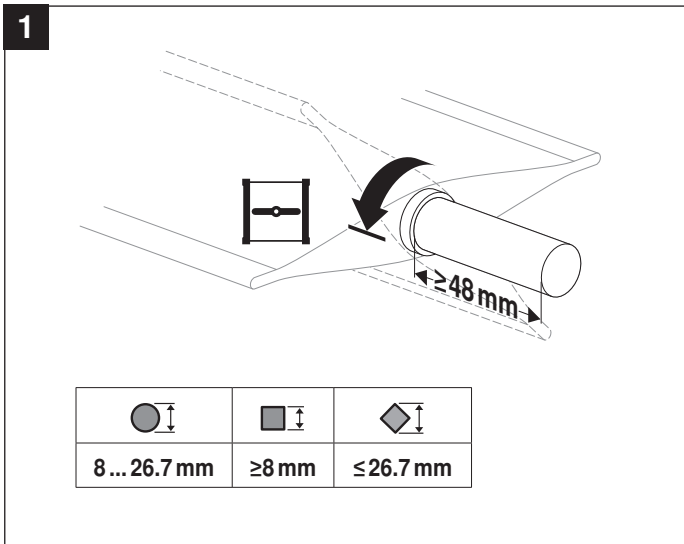
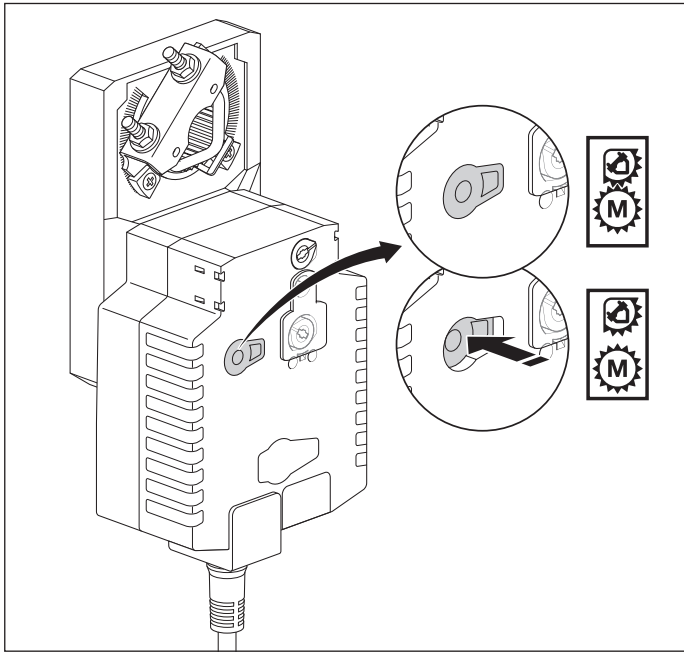



AC 24 V / DC 24 V

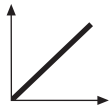
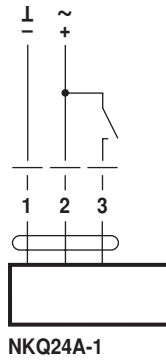

AC 24 V / DC 24 V

