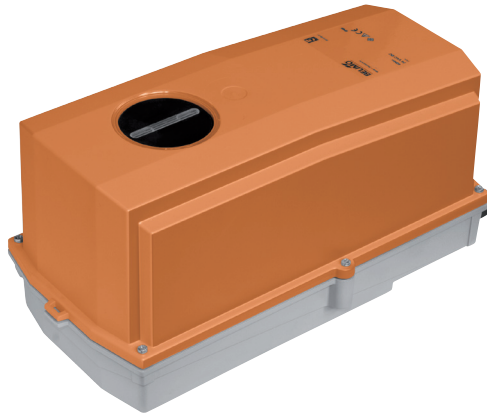

Damper actuator in the IP66 protective housing for adjusting dampers in industrial plants and in technical building installations

- Air damper size up to approx. 8 m²
- Nominal torque 40 Nm
- Nominal voltage AC 230 V
- Control Open-close (unsuitable for 3-point controls)
- Optimum weather protection for use outdoors (for use in ambient temperatures up to -40 °C, there is a separate actuator available with built-in heater ex works)

Technical data

Electrical data	Nominal voltage	AC 230 V
	Nominal voltage frequency	50/60 Hz
	Nominal voltage range	AC 85...264 V
	Power consumption in operation	5 W
	Power consumption in rest position	2.5 W
	Power consumption for wire sizing	9 VA
	Connection supply / control	Terminals 4 mm ² (cable Ø 4...10 mm, 3-wire)
	Parallel operation	Yes (note the performance data)
Functional data	Torque motor	Min. 40 Nm
	Direction of motion motor	selectable with switch 0 (ccw rotation) / 1 (cw rotation)
	Manual override	with push-button, can be locked (under protective housing)
	Angle of rotation	Max. 95°
	Angle of rotation note	can be limited on both sides with adjustable mechanical end stops
	Running time motor	150 s / 90°
	Sound power level motor	45 dB(A)
	Spindle driver	Universal spindle clamp 14...26.7 mm
	Position indication	Mechanically, pluggable
	Safety	Protection class IEC/EN
Protection class UL		II reinforced insulation
Degree of protection IEC/EN		IP66
Degree of protection NEMA/UL		NEMA 4, UL Enclosure Type 4
EMC		CE according to 2014/30/EU
Low voltage directive		CE according to 2014/35/EU
Certification IEC/EN		IEC/EN 60730-1 and IEC/EN 60730-2-14
Certification UL		cULus according to UL 60730-1A, UL 60730-2-14 and CAN/CSA E60730-1:02
Mode of operation		Type 1
Rated impulse voltage supply / control		2.5 kV
Control pollution degree		4
Ambient temperature		-30...50 °C
Ambient temperature note		-40...50 °C for actuator with integrated heating
Non-operating temperature		-40...80 °C
Ambient humidity	100% r.h.	
Maintenance	Maintenance-free	
Weight	Weight	4.2 kg

Safety notes

- The device must not be used outside the specified field of application, especially not in aircraft or in any other airborne means of transport.
- Caution: Power supply voltage!
- Only authorised specialists may carry out installation. All applicable legal or institutional installation regulations must be complied during installation.
- Junction boxes must at least correspond with enclosure IP degree of protection!

Safety notes

- The cover of the protective housing may be opened for adjustment and servicing. When it is closed afterwards, the housing must seal tight (see installation instructions).
- The device may only be opened in the manufacturer's factory. It does not contain any parts that can be replaced or repaired by the user.
- The cables must not be removed from the device installed in the interior.
- To calculate the torque required, the specifications supplied by the damper manufacturers concerning the cross-section, the design, the installation site and the ventilation conditions must be observed.
- The device contains electrical and electronic components and must not be disposed of as household refuse. All locally valid regulations and requirements must be observed.
- The actuator is not designed for applications where chemical influences (gases, fluids) are present or for utilisation in corrosive environments in general.
- The actuator may not be used in plenary applications (e.g. suspended ceilings or raised floors).
- The materials used may be subjected to external influences (temperature, pressure, construction fastening, effect of chemical substances, etc.), which cannot be simulated in laboratory tests or field trials. In case of doubt, we definitely recommend that you carry out a test. This information does not imply any legal entitlement. Belimo will not be held liable and will provide no warranty.
- If cables which are not authorised for UL (NEMA) Type 4 applications are guided out of the unit, then flexible metallic cable conduits or suitable threaded cable conduits of equal value are to be used.

Product features

Fields of application	The actuator is particularly suitable for utilisation in outdoor applications and is protected against the following weather conditions: - UV radiation - rain / snow - dirt / dust - Humidity - Changing atmosphere / frequent and severe temperature fluctuations (recommendation: use the actuator with integrated factory-installed heating which can be ordered separately to prevent internal condensation)
Simple direct mounting	Simple direct mounting on the damper spindle with an universal spindle clamp, supplied with an anti-rotation device to prevent the actuator from rotating.
Manual override	Manual override with push-button possible (the gear is disengaged for as long as the button is pressed or remains locked). The housing cover must be removed for manual override.
Adjustable angle of rotation	Adjustable angle of rotation with mechanical end stops. Standard setting 0 ... 90°. The housing cover must be removed to set the angle of rotation.
High functional reliability	The actuator is overload protected, requires no limit switches and automatically stops when the end stop is reached.

Accessories

	Description	Type
Electrical accessories	Auxiliary switch, add-on, 1 x SPDT	S1A
	Auxiliary switch, add-on, 2 x SPDT	S2A
	Feedback potentiometer 140 Ohm, add-on	P140A
	Feedback potentiometer 140 Ohm, add-on, grey	P140A GR
	Feedback potentiometer 200 Ohm, add-on	P200A
	Feedback potentiometer 500 Ohm, add-on	P500A
	Feedback potentiometer 500 Ohm, add-on, grey	P500A GR
	Feedback potentiometer 1 kOhm, add-on	P1000A
	Feedback potentiometer 1 kOhm, add-on, grey	P1000A GR
	Feedback potentiometer 2.8 kOhm, add-on	P2800A
	Feedback potentiometer 2.8 kOhm, add-on, grey	P2800A GR

Accessories

	Description	Type
	Feedback potentiometer 5 kOhm, add-on	P5000A
	Feedback potentiometer 5 kOhm, add-on, grey	P5000A GR
	Feedback potentiometer 10 kOhm, add-on	P10000A
	Feedback potentiometer 10 kOhm, add-on, grey	P10000A GR
Mechanical accessories	Description	Type
	Cable gland, for cable diameter 4-10 mm	Z-KB-PG11

Electrical installation



Notes

- Caution: Power supply voltage!
- Parallel connection of other actuators possible. Observe the performance data.

Wiring diagrams

AC 230 V, open-close (one-wire) AC 230 V, open-close (two-wire)

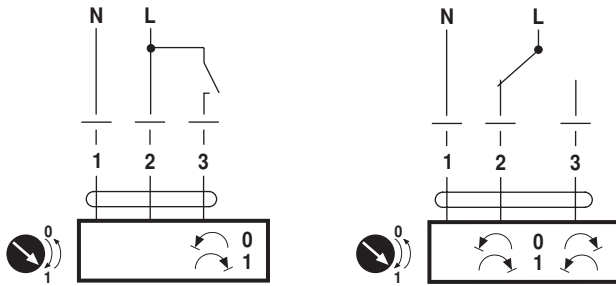

Dimensions [mm]

Spindle length

	-
	16...75

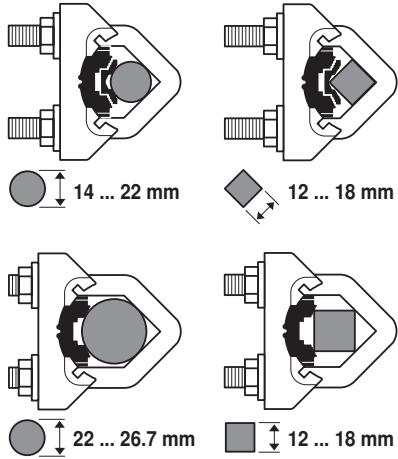

Dimensional drawings

